

INFLUENCE OF DESIGN GROUND MOTION LEVEL ON HIGHWAY BRIDGE COSTS

**REPORT SUBMITTED TO
PACIFIC EARTHQUAKE ENGINEERING RESEARCH (PEER) CENTER
PROGRAM OF APPLIED EARTHQUAKE ENGINEERING RESEARCH
ON LIFELINE SYSTEMS**

PROJECT NUMBER 6D01

by

Mark Ketchum, Ph.D., P.E.
OPAC Consulting Engineers, Inc.

Vivian Chang, P.E.
OPAC Consulting Engineers, Inc.

and

Thomas Shantz, P.E., G.E.
California Department of Transportation

NOVEMBER, 2004

TABLE OF CONTENTS

<u>ITEM</u>	<u>PAGE</u>
1. INTRODUCTION.....	1
1.1 Objectives.....	2
1.2 Bridge Types.....	3
1.3 Approach	4
2. BRIDGE TYPES AND TASKS	8
2.1 Bridge Type Matrix.....	8
2.2 Specific Tasks	13
3. BRIDGE DESIGN AND ANALYSIS	17
3.1 Superstructure Design	17
3.2 Column Size, Geometry, and Fixity	17
3.3 Column Longitudinal Reinforcement.....	17
3.4 Column Lateral Reinforcement.....	18
3.5 Seismic Shear Design for Column	20
3.6 Column Moment Curvature Analysis	21
3.7 Displacement Capacity	22
3.8 Foundation Design	25
3.9 Response Spectrum Analysis	26
3.10 Summary of Analysis Procedure.....	29
3.11 Quantities and Cost.....	30
4. FOUNDATION ASSESSMENT	33
4.1 Cost Analysis.....	33
4.2 Foundation Stiffness.....	39
5. COST VS. GROUND MOTION LEVEL	40
5.1 Bridge 1: Straight CIP PT Box Girder, 150 ft Span, 39 ft Width.....	40
5.2 Bridge 3: Straight CIP PT Box Girder, 100 ft Span, 39 ft Width.....	41
5.3 Bridge 4: Straight CIP PT Box Girder, 100 ft Span, 68 ft Width.....	42
5.4 Bridge 6: Straight Precast PT I Girder, 100 ft Span, 68 ft Width.....	43
5.5 Bridge 9: Curved CIP PT Box Girder, 150 ft Span, 27 ft Width	44
5.6 Bridge 10: Skew CIP PT Box Girder, 100 ft Span, 68 ft Width	45
5.7 Bridge 11: Straight CIP PT Box Girder, 150 ft Span, 39 ft Width, Tall Columns	46
5.8 Comparison of All Evaluated Bridge Types	47
5.9 Lower Limits on Sa and PGA.....	50
6. SUMMARY AND CONCLUSIONS.....	51
6.1 Summary.....	51
6.2 Conclusions	52
6.3 Suggestions for Further Research.....	53
7. ACKNOWLEDGMENTS	54
APPENDIX A: BRIDGE PLANS	A-1
APPENDIX B: FOUNDATION ASSESSMENT CHARTS & TABLES.....	B-1
APPENDIX C: DESIGN SPREADSHEETS	C-1
APPENDIX D: QUANTITY AND COST SUMMARY.....	D-1
APPENDIX E: COST CURVES	E-1

1. INTRODUCTION

Bridge construction costs are influenced by many different design considerations. For example, the unit cost (cost per square foot or square meter of deck area) of a bridge depends upon its span length, structural materials, height, site conditions, foundation materials, etc. Estimation of bridge construction cost based on incomplete information about its design is an important deliverable of advanced planning and preliminary design studies.

One important variable in bridge construction cost is the design seismic ground motion level. Typically, designing for a higher seismic ground motion level – a larger earthquake – results in higher bridge construction cost. Similarly, designing for better structural performance – minimal damage instead of basic life safety/no collapse, for example – results in higher bridge construction cost.

In the planning stages of a bridge construction project, bridge construction costs are typically estimated using rules of thumb such as dollars per square foot for a given type of structure. These estimates allow budgets to be programmed before the bridge design has progressed far enough for more accurate quantities-based estimates to be made.

This report describes a study intended to provide a revised and improved rule of thumb for the influence of design ground motion level on bridge construction cost. The ad-hoc rules of thumb in use before this study were based on previous generations' seismic design criteria, and did not take into account the additional construction costs associated with current seismic design criteria. The revised rules of thumb are intended to allow improved advance planning cost estimates for routine bridges designed to the Caltrans "Ordinary Bridge" performance requirement of the current Caltrans Seismic Design Criteria¹.

The studies reported here can also be used in ongoing efforts to incorporate performance-based design into bridge seismic design criteria. Performance-based design is intended to

allow structures to meet specific performance objectives with greater reliability than the traditional prescriptive code approach. The current Caltrans Seismic Design Criteria incorporate performance-based concepts and is apparently moving towards a more complete performance-based approach. Ongoing research efforts² are furthering performance-based methods to improve the performance, reliability, and economy of bridges in extreme events.

The cost impact of designing to a higher or lower performance level is an important issue to be addressed in further implementation of performance-based design. While the studies here report change in bridge construction cost as influenced by change in design seismic ground motion at a uniform “Ordinary Bridge” level of performance, the suite of data can also be interpreted with respect to change in bridge construction cost as influenced by change in performance criteria. This can be achieved by equating the cost data provided, developed for the same baseline performance at various ground motion levels, to various performance levels at the same ground motions. I.e, designing for one level better seismic performance, where the levels are defined as (a) life safety / no collapse, (b) repairable damage, and (c) minimal damage, is equivalent to designing for roughly 15% to 25% higher ground motions.

1.1 Objectives

It is accepted that for a given structure type, initial construction costs increase as design ground motions increase. The nature of the increase and its differences for various bridge types are not well-understood. Some structural types may also be more amenable to higher seismic ground motion levels than others. This project investigates the seismic ground motion level vs. cost relationship for some of the typical bridge structures used in the California highway system, at typical sites without difficult foundation conditions and without need for extensive site work, designed according to the current Caltrans Seismic Design Criteria to the “Ordinary Bridge” standard.

The project quantifies the construction cost impact of varying levels of design ground motion for new highway bridges. The cost vs. ground motion relationship for typical highway bridges is understood to have a few common features regardless of bridge type:

1. Below some minimum level of design ground motions, there is no reduction of construction cost achieved by further reducing level of design ground motions. The minimum design spectral acceleration is given as 0.1g in the current Caltrans seismic criteria; even at greater ground motions other design issues may control component dimensions and/or costs.
2. At intermediate levels of design ground motions, construction cost increases gradually with increases in level of design ground motions. The cost vs. level of design ground motions relationship may be linear in this region; however there may be changes of slope (cusps) and plateaus associated with various design and/or constructability constraints.
3. Above some relatively high level of design ground motions, construction cost increases rapidly due to ancillary issues. Such issue might include requirements to increase foundation size or deepen the girder and increase post tensioning in order to meet capacity design requirements for resisting column hinging moments.

The cost curve may be influenced by site-specific as well as bridge-type-specific issues. Identification of the shape of the cost curves, the nature of design constraints that define the cusps, and the relative economy of various bridge types at differing ground motion levels are the immediately achievable objectives of this project.

1.2 Bridge Types

Reviewing recent state highway bridge construction in California, it appears that four structure types are dominant:

1. Post-tensioned cast-in-situ concrete box girders on monolithic piers,

2. Pre-tensioned pre-cast concrete I-girders on bearings supported by piers,
3. Concrete slabs on pile extensions, and
4. Steel plate girders on bearings supported by piers.

The concrete box girder and concrete I girder bridges (items 1 and 2 on the above list) are most prevalent. The steel plate girder type has been recently used in high-ground-motion areas with special alignment and/or constructibility constraints. Other types are occasionally used.

It also appears that the following foundation types are dominant for these bridge types:

1. H-piles,
2. Precast concrete piles,
3. Steel pipe piles
4. CIDH shafts

For this study, a screening process of bridge types was applied, to select a short list of candidate bridge superstructure types and configurations to study in detail. This screening process is summarized in Chapter 2 of this report. Foundation types were also determined, and a state-wide averaging process, described in Chapter 4, was applied to account for the various foundation types typically used in California. The screening resulted in focusing this study on concrete box girder and concrete I girder superstructures, on typical foundations used in competent soils.

1.3 Approach

The cost vs. ground motion relationship is influenced by structure-specific issues (superstructure type, span length and arrangement, bent configuration and height, expansion joints, structural period, etc.) as well as site-specific issues (subsurface conditions, variation in bent height over the length of the bridge, etc.).

Comprehensive consideration of all these variables in constructing cost vs. ground motion relationships was outside the scope of this project. For each superstructure type, typical multi-span straight, non-skew bridges with modest-height piers (representative of a simple grade separation) were considered. Curved bridges, skew bridges, and tall bridges were then studied as special cases. This assures meaningful results by concentrating on the most-built typical structural types, and a meaningful framework for follow-up by focusing some effort on the less-frequently-built structural types to assess the overall validity of the model. A detailed description of each bridge type that was considered is presented in Chapter 2.

The overall approach to this study for each bridge type considered included structural type selection, preliminary design, seismic demand and capacity analyses, component detailing, cost estimation, data analysis, and reporting. The key to successful completion, however, was in adopting an efficient approach for evaluating data points on the cost vs. ground motions curve.

In a typical design project, the site's ground motions are identified as response spectra (ARS curves), and the structure is designed and detailed to meet the requirements of the Seismic Design Criteria under those motions. This process typically involves design iterations to meet economy as well as capacity requirements.

To avoid the iterative process in this study, and to provide more data points with the same number of design trials, this process was modified as follows:

1. A basic bridge design was developed, along with a suite of different column or bent designs that can potentially provide varying levels of seismic performance for that basic bridge design.
2. The seismic displacement capacity was evaluated for each column or bent design, using moment-curvature analysis and static push-over analysis.

3. The level of ground motion that would push the column to its displacement capacity was evaluated for each column design, by performing response spectrum analyses under various response spectra (ARS curves) that ranged from 0.1g to 1.0g PGA.
4. Capacity-protected items such as the foundation, bentcap, superstructure, etc. were designed by carrying out a plastic analysis of the bridge and applying SDC-required overstrength factors.
5. Cost estimates were determined by applying unit costs to quantity take-offs.

A detailed description of this procedure as it was developed and followed for this study is presented in Chapter 3.

Within a superstructure type, variations in column sizes and strengths were investigated. For each increment in column size and/or strength, new cost vs. design ground motion data points were generated. The bent or column sizes were selected in an attempt to cover critical points (cusps) on the cost vs. motions curve. The sizes included minimum dimensions and reinforcement per Caltrans design requirements to meet non-seismic and/or minimum-seismic conditions, as well as larger dimensions and reinforcement that defined potential break-points in the cost curve. These break-points included (for example) the column with maximum plastic moment that can be resisted without enlarging the girder, bent cap, pile cap, or foundation; as well as intermediate sizes that meet limitations on vertical or confinement reinforcing.

Foundations contribute significantly to bridge costs and to increased bridge costs due to seismic ground motions. Since Caltrans uses many foundation types under the variety of soil conditions and seismic exposure encountered in the state, a weighted average of foundation properties and costs for various service and seismic loads was developed, based on records of foundation types used in recent bridges. A detailed description of the foundation assessment procedure and its results is presented in Chapter 4.

With this basic approach (for which specific tasks are outlined in the following section) the project focused on balanced seismic performance and on cost vs. ground motions rather than on designing bridges to meet varying ground motion levels. The results of the cost vs. ground motions level studies are presented in a series of figures, with accompanying discussion, in Chapter 5. Thus the purpose of the research could be achieved so that this project provides meaningful results and a basis for any future follow-up research.

¹ Caltrans Seismic Design Criteria Version 1.2 December 2001, California Department of Transportation, Division of Engineering Services, Sacramento, California, December 6, 2001

² Kevin Mackie and Bozidar Stojadinovic, "Probabilistic Seismic Demand Model for California Highway Bridges", Journal of Bridge Engineering -- November/December 2001 -- Volume 6, Issue 6, pp. 468-481

2. BRIDGE TYPES AND TASKS

The bridge structures studied are described in a Bridge Type Matrix that describes their structural system and principal dimensions. The matrix was developed with cooperation of Caltrans supervising staff.

For each bridge structure in the matrix, a common set of engineering tasks was performed, to design and analyze the structure, and define the cost curves.

2.1 *Bridge Type Matrix*

Cast-in-place box girders and precast I/bulb tee girders make up over 90% of new bridge construction in California. Therefore, the study focused on these two types only; slab-on-pile extensions and steel plate girder bridges were eliminated from consideration. Eleven bridge configurations were initially developed for the study and are shown in the Bridge Type Matrix (Table 2.1). The attributes of a single bridge configuration (type of construction, span arrangement, deck width, column size, etc.) were selected as representative of typical statewide bridge construction. The bridges were designed as simplifications of actual structures to eliminate real world complexities that may obscure trends in cost impact and seismic resistance. As the project progressed, four bridge configurations were eliminated due to budget constraints and are shown stricken out in Table 2.1.

Of the final seven bridge configurations examined in the study (Bridge Types 1, 3, 4, 6, 9, 10, and 11), six are cast-in-place post-tensioned box girders and one is a precast pre-tensioned I girder. Each Bridge Type consists of five spans with maximum span lengths of either 100' or 150'. Various deck widths were considered. Bridge Types 1, 3 and 11 are 39' wide and consist of two 12' lanes with 4' left shoulder, 8' right shoulder, Type 732 or 736 barrier at each side and single column bents. Bridge Types 4, 6 and 10 are 68' wide and consist of four 12' lanes, 4' shoulders, Type 26 sidewalk with barrier at each side and multi-column bents. Bridge Type 9 is 27' wide and consists of one 12' lane with 4' left shoulder, 8' right

shoulder, Type 732 or 736 barrier at each side and single column bents. Bridge Type 9 was placed on a 1000' radius curve and Bridge Type 10 was placed on a 30° skew to test the influence of curvature and skew angle. A column height of 22' was used throughout except for Bridge Type 11 which has a column height of 50' to test the influence of tall columns.

Elevation and cross sections of the final seven bridges are shown in the following Figures. More complete drawings are included in Appendix A.

Table 2.1: Bridge Type Matrix

Bridge Type	Structure Type	Geometry	Deck Width	Deck Depth	Span Arrangement	Bent Columns	Column Height
1	CIP/PS box	Straight	39'	6'	120'+150'+150'+150'+120'	1	22'
2	CIP/PS box	Straight	68'	6'	120'+150'+150'+150'+120'	3	22'
3	CIP/PS box	Straight	39'	4'	80'+100'+100'+100'+80'	1	22'
4	CIP/PS box	Straight	68'	4'	80'+100'+100'+100'+80'	3	22'
5	PC/PS girder	Straight	39'	5'-2"	80'+100'+100'+100'+80'	1	22'
6	PC/PS girder	Straight	68'	5'-2"	80'+100'+100'+100'+80'	3	22'
7	PC/PS girder	Straight	39'	6'-2"	120'+120'	1	22'
8	PC/PS girder	Straight	68'	6'-2"	120'+120'	3	22'
9	CIP/PS box	1000' radius	27'	6'	120'+150'+150'+150'+120'	1	22'
10	CIP/PS box	30° skew	68'	4'	80'+100'+100'+100'+80'	3	22'
11	CIP/PS box	Straight	39'	6'	120'+150'+150'+150'+120'	1	50'

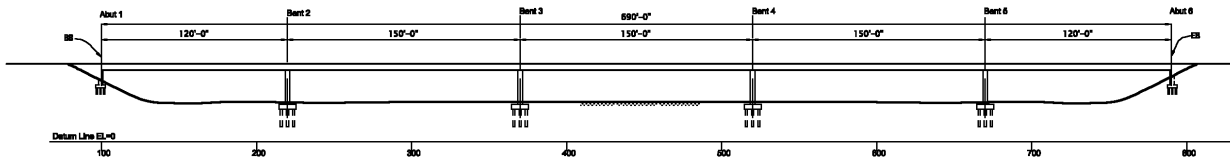

Elevation
Scale: 1"=30'-0"

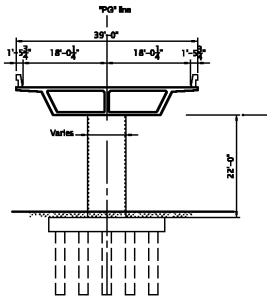

Typical Section
Scale: 1"=10'-0"

Bridge Type 1: Straight Cast-In-Place Post-Tensioned Box Girder, 150 ft Span, 39 ft Width

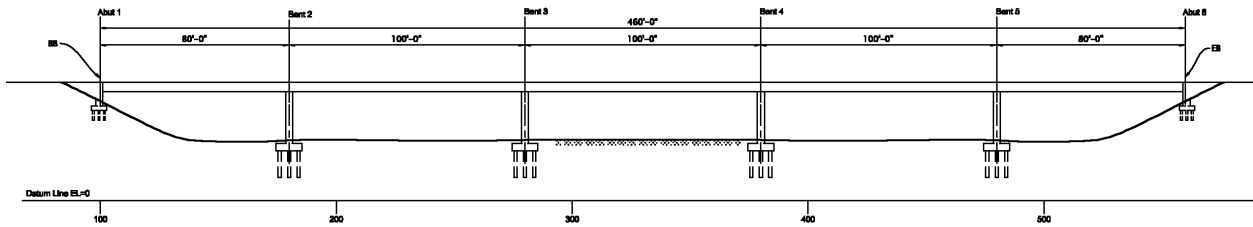

Elevation
Scale: 1"=30'-0"

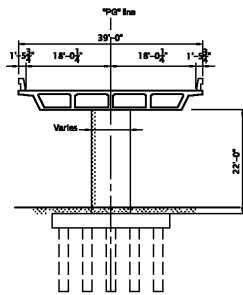

Typical Section
Scale: 1"=10'-0"

Bridge Type 3: Straight Cast-In-Place Post-Tensioned Box Girder, 100 ft Span, 39 ft Width

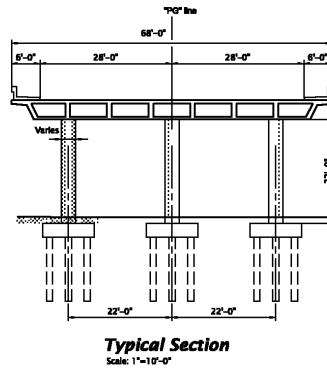
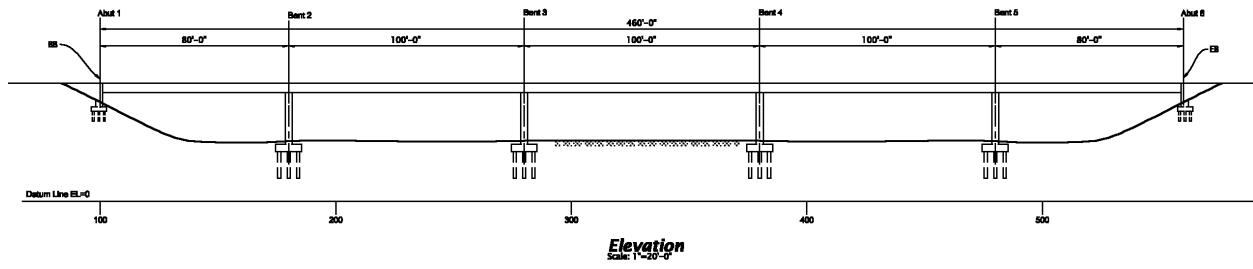

Bridge Type 4: Straight Cast-In-Place Post-Tensioned Box Girder, 100 ft Span, 68 ft Width

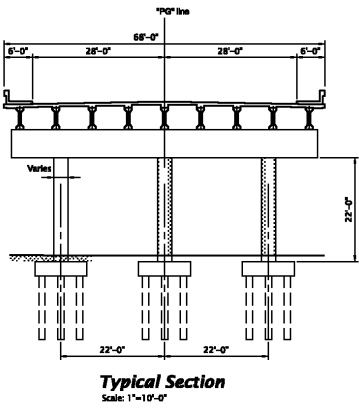
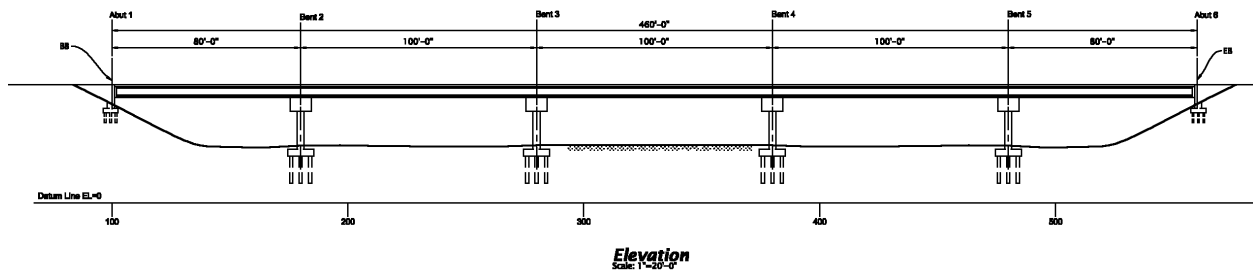

Bridge Type 6: Straight Precast Pre-tensioned I Girder, 100 ft Span, 68 ft Width

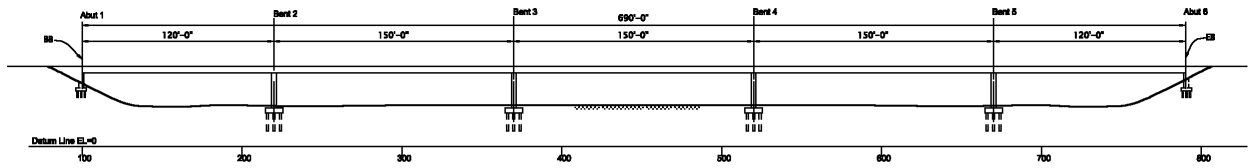

Elevation

Scale: 1"=30'-0"

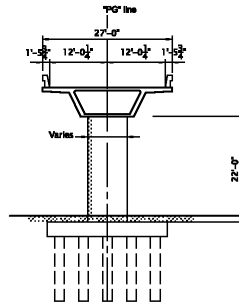

Typical Section

Scale: 1"=10'-0"

Bridge Type 9: Curved Cast-In-Place Post-Tensioned Box Girder, 150 ft Span, 27 ft Width

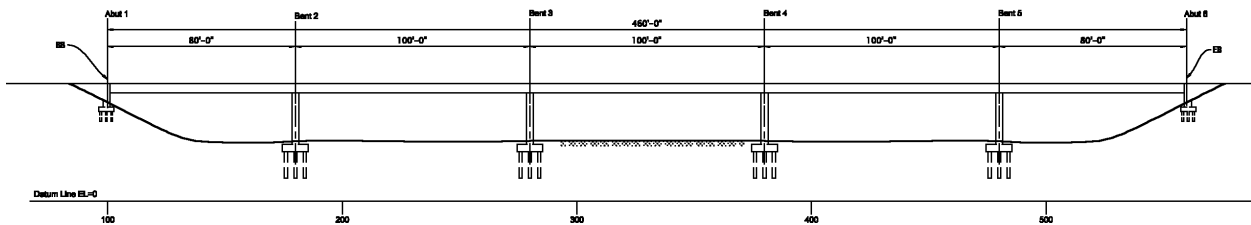

Elevation

Scale: 1"=20'-0"

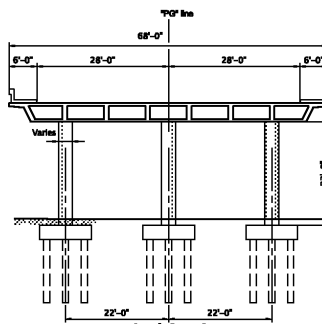

Typical Section

Scale: 1"=10'-0"

Bridge Type 10: Skew Cast-In-Place Post-Tensioned Box Girder, 100 ft Span, 68 ft Width

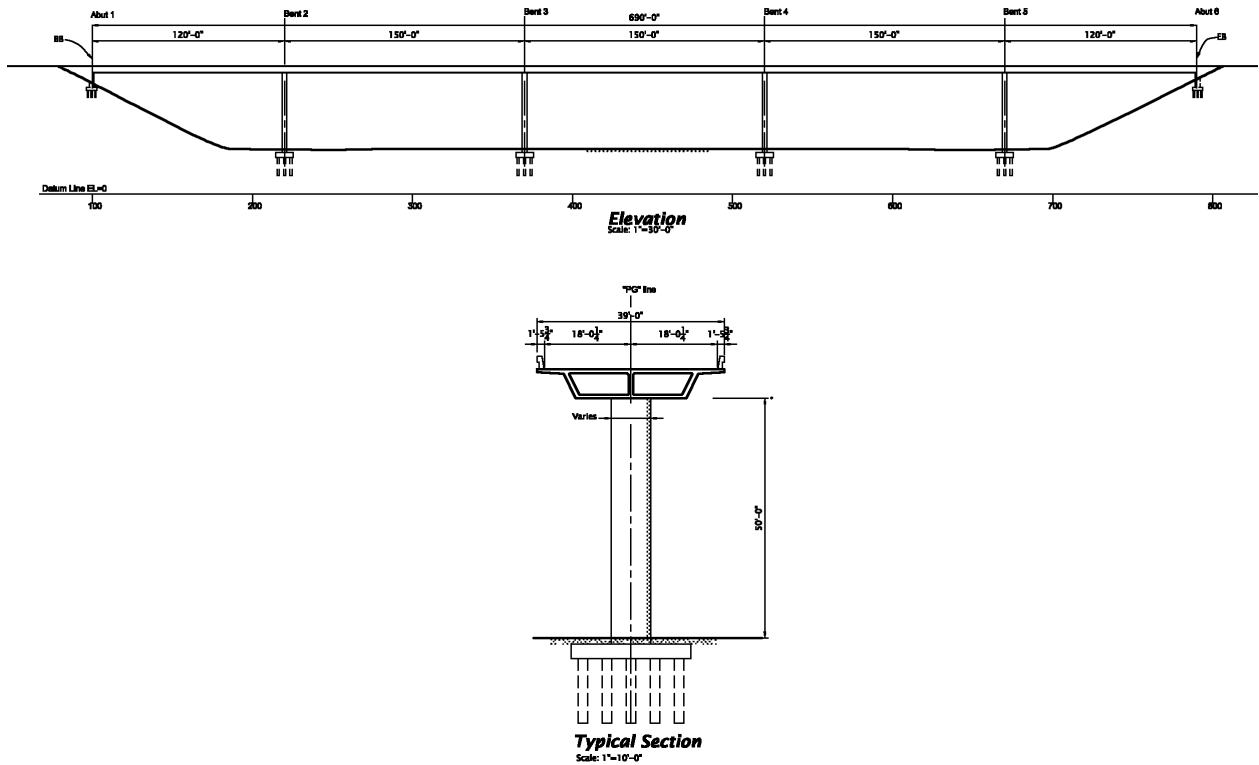

Bridge Type 11: Straight Cast-In-Place Post-Tensioned Box Girder, 150 ft Span, 39 ft Width, Tall Columns

2.2 Specific Tasks

The following specific tasks were undertaken in development of the cost curves for each selected bridge type. The technical details of these tasks and their implementation are described in Chapter 3.

1. Prepare preliminary designs of each bridge to dimension principal components to a nominal level of seismic resistance. The designs are in strict compliance with Caltrans standards, including minimum and maximum dimensions of columns.
2. Prepare seismic demand computer models of each bridge, conforming to the Caltrans Seismic Design Criteria and Caltrans practice. These consist of three-dimensional elastic dynamic frame-element models with uncracked properties in the superstructure,

cracked properties in the bents, linearized abutment stiffness, and linearized foundation springs. SAP2000 was used for the modeling.

3. Prepare seismic capacity computer models for each bridge, conforming to the Caltrans Seismic Design Criteria and Caltrans practice. These consist of inelastic push-over models of bents. The push-over models make use of xSection for moment-curvature analysis and spreadsheet programs for pushover analysis. Other capacities were evaluated by hand or with Excel or Mathcad templates.
4. Select a suite of bent or column dimensions for which the seismic resistance level is evaluated. These dimensions span a range from smallest practical (that required to resist safely non-seismic loads) to maximum feasible (for example where girder or footing dimensions must be increased significantly to meet capacity-based design requirements) with varying reinforcement at each dimension. Dimensions were generally constrained to the SDC Eq. 7.24 recommendation of $2/3 < D_c/D_s < 4/3$. Spectral acceleration levels beyond 2 g were not considered.
5. For each bridge and for each member of the suite of bent dimensions, perform the following tasks to estimate the ground motion that can be resisted to Caltrans Seismic Criteria standards for bridges designated as “Ordinary Bridges”:
 - a. Perform a moment-curvature analysis of column sections; reporting these items:
 - i. Maximum curvature to meet performance requirements, governed by strain limits.
 - ii. Maximum hinge rotation compatible with maximum curvature.
 - iii. Plastic moment (overstrength capacity) for design of capacity protected components.
 - iv. Effective bending stiffness for use in global modeling and analysis

- b. Design capacity protected components such as footings, pile shafts, bent cap beams, joints, superstructure girders, and column shear reinforcement, to remain essentially elastic when the column reaches its overstrength capacity.
 - c. Revise the seismic demand model (see item 2) to incorporate linearized stiffnesses of columns, abutments, and foundations and perform response spectra analyses to provide displacement demands on bents and other displacement controlled components, and force demands on abutments, foundations, and other force controlled components.
 - d. Revise displacement capacity (push-over) models (see item 3) to incorporate moment-curvature relationships and hinge rotation capacities, and perform push-over analyses of bents to provide displacement capacities of bents.
 - e. Compare displacement demands from (c) with displacement capacities from (d) to determine spectra applicable to the bridge. This spectra represents the level of ground motion that can be resisted by the given design from the suite of bent dimensions.
 - f. Verify the dimensions of force-controlled components such as foundations, per Seismic Design Criteria requirements. Verify the dimensions of service load-controlled components such as abutments. Reanalyze (c-e) if necessary to validate spectra multiplier.
 - g. Estimate construction cost by performing material quantity take-offs and applying agreed-upon (Caltrans standard) unit costs.
6. Plot the cost vs. spectral acceleration and cost vs. peak ground acceleration data to illustrate the project objective for the bridge type.

Bridge Type 4 (the straight, cast-in-place, post-tensioned box girder with 100 ft span and 68 ft width) was chosen to be a Test Model for development of these tasks. The design and analyses of the Test Model were carried out and refined, to arrive at the general procedure specified above and described in detail in Chapter 3, prior to proceeding with the design and analyses of the other bridge types.

3. BRIDGE DESIGN AND ANALYSIS

For each bridge in the bridge type matrix (Chapter 2), the following procedure was followed to design the bridge, evaluate seismic resistance, and estimate costs. The bridge designs were developed to be in compliance with Caltrans standards for “Ordinary Bridges”, including the philosophy of weak column-strong beam seismic design. In a severe earthquake, the column is designed to yield and dissipate input energy in a controlled manner, while the foundation and superstructure remain essentially elastic.

3.1 Superstructure Design

The prestressed box girders and precast I girders were designed in accordance with BDS³, MTD⁴, BDA⁵ and BDD⁶. Mild steel reinforcement was provided over the bents to ensure that the nominal strength of the superstructure exceeds the column over strength demands. In accordance with MTD 20-6, the minimum mild steel reinforcement provided over the bents was #8 at 12” in the top and bottom slabs. Joint shear reinforcement was provided in accordance with SDC⁷ section 7.4.

3.2 Column Size, Geometry, and Fixity

For multi-column bents, only circular columns were considered. For single column bents, both circular and oblong columns were considered. The range of column sizes considered for each particular Bridge Type was based on the guideline given in SDC equation 7.24: $0.67 < D_c/D_s < 1.33$.

In multicolumn bents, columns were pinned at the base and fixed at the top. In single column bents, columns were fixed at both the base and the top.

3.3 Column Longitudinal Reinforcement

SDC Section 3.7 states that the minimum and maximum longitudinal reinforcement ratios shall not be less than 0.01 or greater than 0.04. Experience has shown that a

longitudinal reinforcement ratio of 0.04 leads to a highly reinforced column with concrete placement difficulties. Therefore, a maximum longitudinal reinforcement ratio of 0.03 was used along with a minimum longitudinal reinforcement ratio of 0.01.

SDC Section 3.5 states that columns shall have a minimum lateral flexural capacity to resist a lateral force of $0.1 \times P_{dl}$ where P_{dl} is the tributary dead load applied at the center of gravity of the superstructure. Columns incapable of resisting this lateral force were removed from consideration.

Consultations with Caltrans supervising staff concluded that lateral flexural capacity to resist a lateral forces greater than $2.0 \times P_{dl}$ is not of interest because such high spectral accelerations (greater than 2g) are not typically encountered in California for the range of structural periods considered. Columns capable of resisting lateral forces greater than this value were therefore not included in the study.

3.4 Column Lateral Reinforcement

The lateral reinforcement provides confinement that increases the strength and ultimate compressive strain capacity of the confined concrete, and provides more ductile column behavior. Strength increases of 30% to 50% are not unusual for well confined sections. The post-yield performance of the column is largely dependent on the volume of hoop steel and its ability to extend the concrete stress-strain relationship by confinement. Several formulas were taken into consideration in designing the lateral reinforcement:

$$\text{BDS eq. 8-62:} \quad \rho_s = 0.45 (A_g/A_c - 1) f'_c/f_y$$

$$\text{BDS eq. 8-62A:} \quad \rho_s = 0.45 (A_g/A_c - 1) f'_c/f_y [0.5 + (1.25P_e)/(f'_c A_g)]$$

for columns 3' or less

$$\text{BDS eq. 8-62B:} \quad \rho_s = 0.12 f'_c/f_y [0.5 + (1.25 P_e)/(f'_c A_g)]$$

for columns larger than 3'

Priestley eq. 5.47⁸: $\rho_s = 0.16 f'_{ce}/f_{ye} [0.5 + (1.25 P_e)/(f'_{ce}A_g)] + 0.13 (\rho_l - 0.01)$

Priestley eq. 5.56⁹: $\rho_s = 0.0002n$

The column lateral reinforcement used in the bridge designs was taken from the governing equation BDS requirements where applicable, and from the Priestley equations where they appeared to govern.

BDS equation 8-62 is taken from ACI-318. The amount of spiral reinforcement required by this formula is intended to provide additional load-carrying strength for concentrically loaded columns equal to or slightly greater than the strength lost when the shell spalls off.

BDS equations 8-62A and 8-62B are based on testing of reinforced columns at the University of Canterbury in New Zealand which has shown that the required confinement of column reinforcement is directly proportional to the axial load applied.

Priestley equation 5.47 is similar to BDS equation 8-62B except that f'_{ce} and f_{ye} represent expected concrete compression and steel yield strengths. Since ductility capacity is expected to be reduced with high axial loads or reinforcement ratios, it is suggested that levels of confining reinforcement be increased by one-third and that a further increase be required for columns with high longitudinal steel ratio. Priestley equation 5.56 is based on the amount of transverse reinforcement required to restrain the longitudinal steel against buckling. This requirement can be onerous when large numbers of longitudinal reinforcing bars are used and need not be applied to columns with aspect ratio of $M/VD < 4$.

It was assumed that the maximum confinement bar size and minimum spacing would be limited to #8 at 3". For large columns with fixity at both ends, the shear demand V_o

= $2M_o/L$ can be quite high. In instances where the required shear reinforcement exceeded #8 at 3", these columns were removed from consideration.

Within the plastic hinge length, the minimum volume of lateral reinforcement required by SDC equation 3.31 is $\rho_s = (4A_b)/(D's)$ where D' is the diameter of the core measured from center to center of hoops. Again, columns were removed from consideration when the required volume of lateral reinforcement exceed #8 at 3".

In the course of the study, several 6' and 7' diameter columns were initially considered. It was found that the 7' diameter columns would need a steel jacket in the plastic hinge zone in order to satisfy the volume of lateral reinforcement required by SDC. However, the xSection moment curvature analysis showed that the longitudinal tensile reinforcement was fracturing before the enhanced ultimate concrete strain could be taken advantage of. Large diameter columns with shallow compression zones may be controlled by tensile fracture of rebar before the advantageous effect of increased concrete strain can be utilized. There the plastic hinge rotation and displacement capacity of these columns is limited. These columns were ruled out due to poor deformation capacity and are not considered in the findings of this study.

3.5 Seismic Shear Design for Column

In the plastic hinge zone, the concrete shear capacity was calculated in accordance with SDC section 3.6.2 where $V_c = v_c A_e$, effective shear area $A_e = 0.8A_g$, and $v_c = \text{Factor 1} \times \text{Factor 2} \times \sqrt{f'_c}$. Factor 1 = $\rho_s f_{yh}/150 + 3.67 - \rho_d < 3$ and ≥ 0.3 . Factor 2 = $1 + P_c/(2000A_g) \leq 1.5$. If the net axial load on the column is tensile (i.e. if the column is under net uplift), then $v_c = 0$ and $V_c = 0$, and all shear is resisted by lateral reinforcement.

For confined circular or interlocking core sections, the shear reinforcement capacity was calculated in accordance with SDC section 3.6.3 where $V_s = A_v f_{yh} D'/s$, $A_v = n (\pi/2)$

A_b , and n = number of spiral or hoop core sections. In circular columns, $n = 1$. In oblong columns, $n = 2$ in both the strong direction and the weak direction.

Column lateral reinforcement design is controlled by three criteria: 1) required ρ_s ; 2) providing V_s such that $\phi V_n > V_u$, and 3) the minimum ductility capacity requirement of SDC Section 4.1 that must be satisfied and is discussed in Section 3.7 of this Chapter.

3.6 Column Moment Curvature Analysis

The xSection computer program for moment curvature analysis was used to calculate I_{cr} , M_p , ϕ_y , and ϕ_u . The M - ϕ curve generated by xSection was simplified to an idealized elastic-plastic curve, per current bridge design practice. In general, two analyses were performed for each column section:

1. When calculating I_{cr} and M_p , the average compression DL + EQ axial force was used. This simplified both the selection of the cracked section properties for the dynamic analysis, and the plastic analysis of multicolumn bents.
2. When calculating ϕ_y and ϕ_u , the maximum compression DL + EQ axial force was used. It was important to account for the effect of compression on the deformation capacity of the plastic hinge. Since the displacement capacity of a frame is defined by the rotational capacity of the first plastic hinge, the yield curvature and ultimate curvature were accurately modeled.

The vertical and lateral distributions of forces to satisfy equilibrium requirements in single-column (fixed-base) bents and multi-column (pinned-base) bents are illustrated in Fig. 3.1a and Fig. 3.1b. For cantilever columns, $V_p = M_p/L$. For columns with fixity at both ends, $V_p = 2M_p/L$. A column overstrength factor was used to determine force demands per SDC equation 4.4: $M_o = 1.2M_p$. Likewise, $V_o = 1.2V_p$.

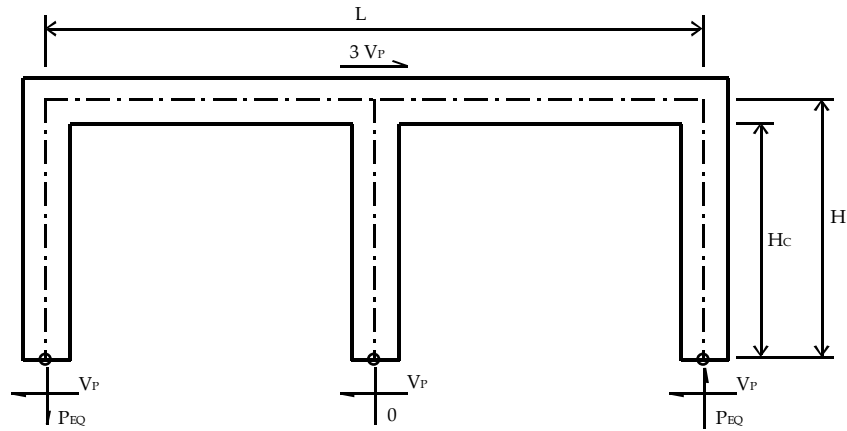

M_p = Plastic Moment based on Average ($P_{DL} + P_{EQ}$)
 $M_0 = 1.2 M_p$
 $V_p = M_p / H_c$
 $V_0 = 1.2 V_p$
 $P_{EQ} = 3 M_0 H / (H_c L)$

Fig. 3.1a Plastic Analysis, Multi-Column Bent

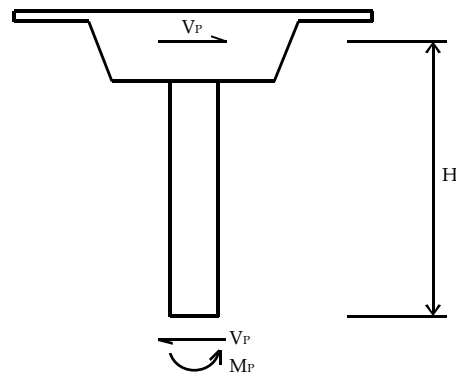

M_p = Plastic Moment based on Average ($P_{DL} + P_{EQ}$)
 $M_0 = 1.2 M_p$
 $V_p = 2 M_p / H$
 $V_0 = 1.2 V_p$
 $P_{EQ} = 0$

Fig. 3.1b Plastic Analysis, Single-Column Bent

3.7 Displacement Capacity

Displacement capacities of the columns and bents were evaluated using push-over analyses that take into account the geometry and boundary conditions of the bent, the ultimate curvature capacities of the columns, the specific requirements of SDC Section 4.1, and P-Δ effects.

The SDC Section 4.1 outlines 3 part criteria for column displacement capacity.

1. Part 1 is the global displacement criteria, which requires that $\Delta_D < \Delta_C$.
2. Part 2 is the demand ductility criteria, which requires that the target displacement ductility demand, μ_D , must be less than or equal to 4 for single column bents and less than or equal to 5 for multi-column bents.
3. Part 3 is the ductility capacity criteria, which requires that minimum local displacement ductility capacity, μ_C , must be greater than 3 regardless of ductility demand.

Each of these criteria represented a boundary to the range of acceptable designs. These boundaries and their influences of the bridge designs are discussed below.

1. Global Displacement Criteria

The global displacement criteria requires that the global displacement capacity exceed the global displacement demand. While this is a fundamental criterion (capacity must always equal or exceed demand in structural design), an interesting problem of definition developed as a result of a simplification made in the foundation model.

The global displacement defined as the sum of footing displacement and column displacement where $\Delta_{\text{global}} = \Delta_{\text{footing}} + \Delta_{\text{col}}$. In this study, the same elastic foundation springs were used in both the demand-side modeling and the capacity-side modeling, as a result of the “state average” foundation consideration. In an elastic response spectrum analysis, the base shear can be several times greater than the plastic shear in the inelastic pushover analysis. When using the same elastic foundation spring in both analyses, the foundation displaces different amounts in each analysis. Since the footing displacements obtained from the response spectrum analysis can be several

times larger than those obtained from the inelastic pushover analysis, it would not be an “apples to apples” comparison to compare global displacements.

Therefore, the displacement demand and displacement capacity were taken to be that of the column only. Foundation and bent cap flexibility were included in the modeling and analysis for displacement demands and capacities, but footing displacements were not considered in the global displacement comparisons. The “equal displacement observation” was interpreted as equal column drifts.

2. Target Ductility Demand Criteria

The target displacement ductility demand $\mu_D = \Delta_D / \Delta_Y$. Since the columns were pushed to their capacity, the displacement demand was taken equal to the displacement capacity so $\mu_D = \mu_C = \Delta_C / \Delta_Y$. The global frame displacement capacity $\Delta_C = \Delta_{y,col} + \Delta_{p,col} + \Delta_{y,footing}$. The yield displacement of the subsystem from its initial position to the formation of plastic hinge $\Delta_Y = \Delta_{y,col} + \Delta_{y,footing}$.

In some single column bent models, μ_C was greater than 4. When this occurred, the usable column displacement capacity was capped in which case $\Delta_{y,col} + \Delta_{p,col} = 4(\Delta_{y,col} + \Delta_{y,footing}) - \Delta_{y,footing}$ or $\Delta_{y,col} + \Delta_{p,col} = 4\Delta_{y,system} - \Delta_{y,system} + \Delta_{y,col}$.

3. Ductility Capacity Criteria

The local displacement ductility capacity $\mu_C = (\Delta_{y,col} + \Delta_{p,col}) / \Delta_{y,col}$. In a few instances, initial evaluations of the designs indicated that the minimum local displacement ductility capacity was less than 3. In these instances, the lateral reinforcement was increased in order to achieve a minimum local displacement ductility capacity of 3.

P-Δ Effects

P-Δ effects on the capacity side were accounted for by modifying the basic bilinear lateral force vs. lateral displacement model to account for the changing equilibrium

equations of the system as lateral displacements increase. The now-standard approach was used, resulting in the revised lateral force vs. lateral displacement relationship illustrated in Fig. 3.2.

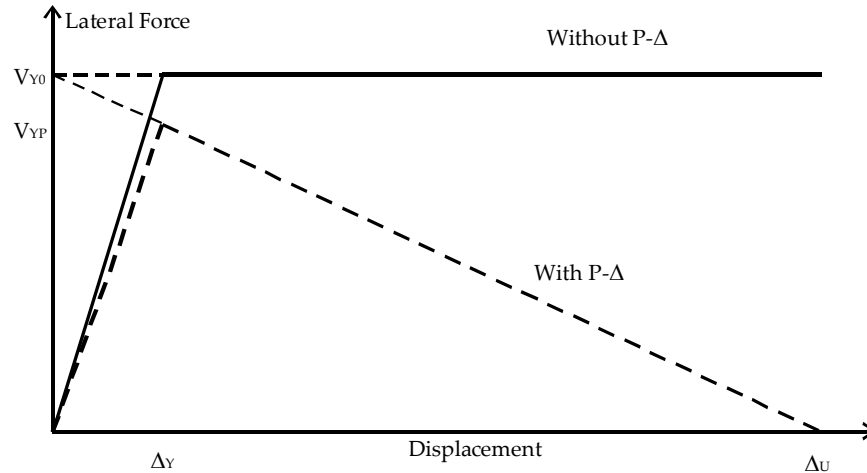

Fig. 3.2 P- Δ Influence on Displacement Capacity

3.8 Foundation Design

Four foundation classes were considered: H-piles, precast concrete piles, steel pipe piles, and cast-in-drilled hole (CIDH) shafts. The column axial load and M_o were used to determine the pile group size, foundation springs and cost.

For fixed base columns, the pile/shaft group size was taken from the table in the “Foundation Cost Analysis” report for single column footings. For pinned base columns, the pile/shaft group size was taken from the charts in the “Foundation Cost Analysis” report for multi-column bents. The foundation stiffness used in the analyses was taken to be a weighted average of the foundation stiffness of the various pile/shaft classes with the exception of precast concrete piles.

The Precast concrete piles were excluded from the weighted averaging because the foundation stiffness for the precast concrete piles was significantly softer than the foundation stiffness for the other pile/shaft classes. It was determined that this softer foundation did not affect the shape of the cost versus ground motion curve but tended

to shift the curve slightly toward higher ground motions at a given cost. Therefore, the precast concrete pile option was excluded from the foundation stiffness analyses. The precast concrete pile option was, however, included in the foundation cost analyses: The foundation cost was taken to be a weighted average of the foundation cost of all four pile classes.

The spring stiffness of the abutment foundation in the longitudinal direction was found to be governed by the formula $K_{res} = 0.1 * K_{eff}$ in SDC Sect. 7.8.1 where K_{eff} is the passive pressure resistance on the abutment backwall. The spring stiffness of the abutment foundation in the transverse direction was taken to be K_{nom} per SDC Sect. 7.8.2 where K_{nom} is 50% of the transverse stiffness of the adjacent bent.

3.9 Response Spectrum Analysis

Longitudinal and transverse response spectrum analyses for each model were performed utilizing SAP2000. For each bridge type and column, a three-dimensional SAP2000 model of the bridge was developed using cracked section properties for the columns, uncracked section properties for the superstructure, and foundation and abutment springs per the foundation design. The SAP2000 bridge model for Bridge Type 4 is shown in Fig. 3.3.

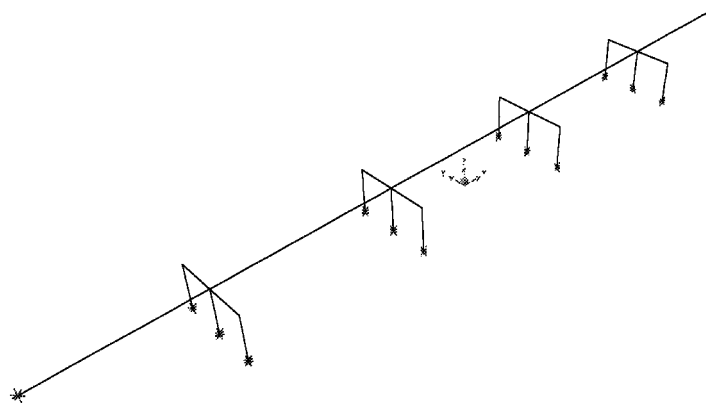

Fig. 3.3 SAP2000 Analysis Model for Bridge Type 4

During development of the analysis procedures on Bridge Type 4, simpler bridge models were considered and tested as alternatives to the three-dimensional modeling with SAP2000 or equivalent programs. The simpler models generally consisted of accurate models of a single bent, carrying the tributary mass of the deck and with appropriate boundary conditions to represent a segment of the entire structure. Cost evaluations based on such simpler modeling were compared with those based on the three-dimensional modeling to determine whether such simpler modeling would suffice for the purposes of this research. It was found that for relatively small earthquakes, the two models resulted in similar cost estimates. For larger earthquakes, however, the simpler model resulted in significantly higher costs. Therefore the simpler models were abandoned and all results presented here are based on the three-dimensional modeling with SAP2000.

The SDC ARS curves for soil profile Type D with magnitudes of 6.5, 7.25 and 8.0 were used. The peak ground accelerations were extrapolated to 1.0g by first normalizing the ATC-32 curves by their corresponding peak bedrock acceleration (PBA), and then, for each period, extending the normalized spectra beyond 0.7g. This worked very well for the M7.25 and M8 curves. For the M6.5 curves, some further adjustment was required to achieve reasonable spectral accelerations for periods below 1 second. Plots of spectral acceleration $S_a(g)$ vs. structural period T (seconds) for the three magnitude earthquakes are shown in Fig. 3.4a, b, and c.

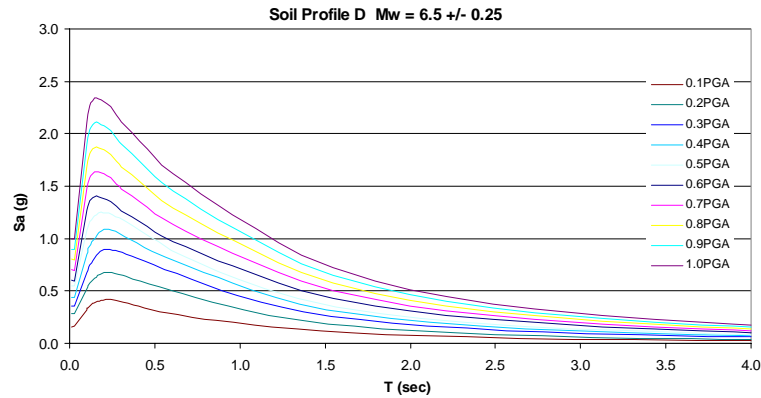

Fig. 3.4a Spectral Acceleration vs. Period, Mw=6.5

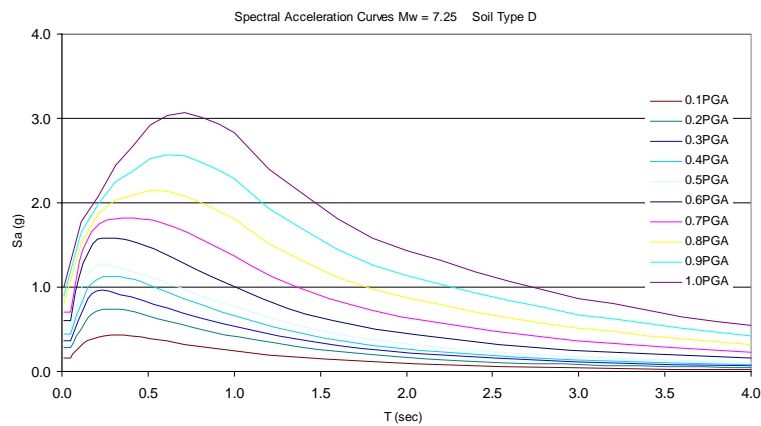

Fig. 3.4b Spectral Acceleration vs. Period, Mw=7.25

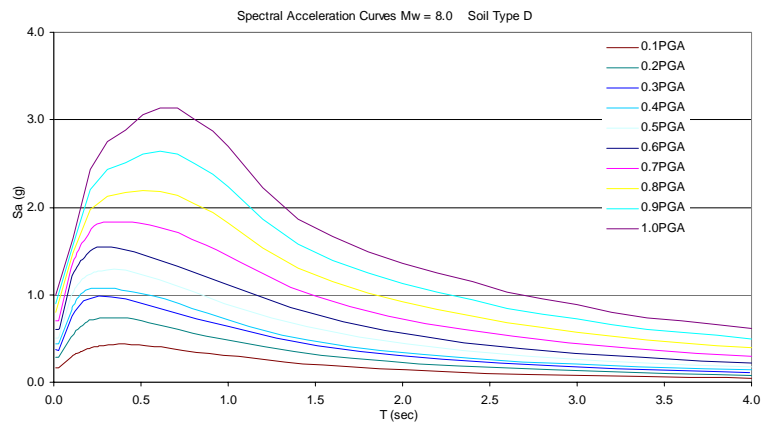

Fig. 3.4c Spectral Acceleration vs. Period, Mw=8.0

The displacement demands for each column type were calculated from the displacement of the top of the column relative to the column base. Since the columns were pushed to their capacity, the displacement demand was set equal to the

displacement capacity in order to determine the equivalent peak ground acceleration (PGA) and spectral acceleration (Sa) associated with the column displacement capacity. For a given column in a given bridge type, the spectral acceleration was the same for all three magnitude earthquakes while the peak ground acceleration decreased with increasing magnitude of earthquake because of the differing shapes of the spectra. The level of ground motion that could be accommodated by a given bridge type tended to increase with increasing column strength.

3.10 Summary of Analysis Procedure

The procedure for mapping the response spectrum analysis results and the pushover results together to find the maximum earthquake PGA and Sa in each direction (longitudinal and transverse) that can be resisted to the SDC by the given bridge design and a given earthquake magnitude is summarized below and in Fig. 3.5.

1. A suite of response spectrum analyses was performed using input ARS curves for PGA ranging from 0.1g to 1.0g in 0.1g increments. The results of these analyses were post processed to provide tables of PGA vs. column displacement demand and PGA vs. elastic base shear.
2. Moment-curvature analyses and pushover analyses were performed to provide a column displacement capacity for the design.
3. The PGA vs. displacement demand table (from step 1) was entered with the displacement capacity value (from step 2). A value of maximum PGA resisted by the design was evaluated by interpolation.
4. The PGA vs. elastic base shear table (from step 1) was entered with the maximum PGA value (from step 3). A value of elastic base shear at maximum PGA was evaluated by interpolation.

5. A value of maximum S_a resisted by the design was evaluated by dividing the interpolated elastic base shear (from step 4) by the weight of the structure.

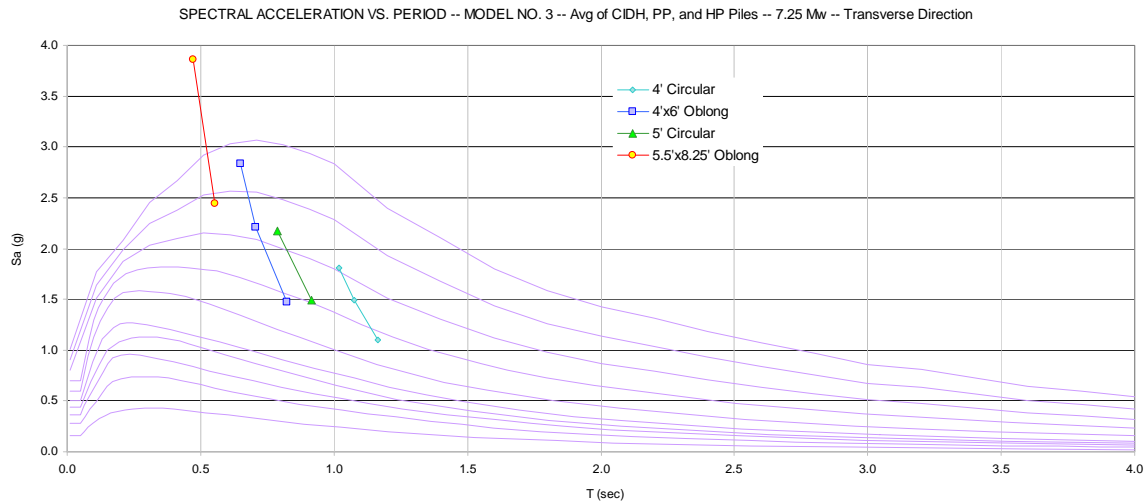

Fig. 3.5: Interpolating maximum PGA and S_a

3.11 Quantities and Cost

The cost of each bridge was estimated using a quantities and unit cost approach. The quantities that increased with column size and strength were bent cap concrete, column concrete, footing concrete, column reinforcing, footing reinforcing, additional superstructure reinforcing at the bents, and number of piles. An average abutment and wingwall size was assumed and the quantities for them were assumed to remain constant for a given Bridge Type.

The foundation cost is based on a weighted average of the cost of four commonly used pile types: H-piles, precast concrete piles, steel pipe piles, and cast-in-drilled-hole piles, as discussed in Chapter 4 of this report.

Estimated 2003 unit costs provided by Caltrans estimators (Table 3.1) were applied to determine the estimated construction cost of each bridge model. The estimated cost was plotted against spectral acceleration as well as peak ground acceleration.

Table 3.1: Estimated unit costs

ITEM	Unit	Price
Structure Excavation (Bridge)	CY	\$50
Structure Backfill (Bridge)	CY	\$65
Furnish Precast Prestressed Concrete Girder (100')	FT	\$145
Erect Precast Prestressed Concrete Girder	EA	\$2,000
Prestressing Cast-in-Place Concrete	LB	\$1.05
Structural Concrete, Bridge Footing	CY	\$310
Structural Concrete, Bridge	CY	\$445
Joint Seal (Type B - MR 2")	FT	\$50
Bar Reinforcing Steel	LB	\$0.65
Chain Link Railing Type 7	FT	\$40
Concrete Barrier (Type 26)	FT	\$85
Concrete Barrier (Type 732)	FT	\$75

³ Caltrans Bridge Design Specifications, LFD Version, April 2000, California Department of Transportation

⁴ Caltrans Memo to Designers, California Department of Transportation

⁵ Caltrans Bridge Design Aids, California Department of Transportation

⁶ Caltrans Bridge Design Details, California Department of Transportation

⁷ Caltrans Seismic Design Criteria Version 1.2 December 2001, California Department of Transportation, Division of Engineering Services, Sacramento, California, December 6, 2001

⁸ M.J.N. Priestley, F. Seible and G.M. Calvi, "Seismic Design and Retrofit of Bridges", John Wiley & Sons, 1996, pp. 218,313 & 317

⁹ M.J.N. Priestley, F. Seible and G.M. Calvi, "Seismic Design and Retrofit of Bridges", John Wiley & Sons, 1996, pp. 218,313 & 317

4. FOUNDATION ASSESSMENT

Foundation assessment was performed by Caltrans supervising staff to provide designs and costs for varying vertical and lateral loads, representative of average conditions encountered across the State.

4.1 Cost Analysis

Experience tells us that foundations contribute significantly to increased bridge cost resulting from increased levels of seismic design loading. Since Caltrans uses many foundation types and faces a wide variety of soil conditions throughout the state, one struggles to devise a representative bridge foundation that adequately captures, in an average sense, the influence of seismic design loads on overall bridge cost.

4.1a. Strategy

The strategy utilized for this study is as follows:

1. Identify pile classes and use construction spending data to determine relative use

Four pile classes were considered: H-piles, precast concrete piles, steel pipe piles, and cast-in-drilled hole (CIDH) piles (sometimes called drilled shafts). Construction spending data from 1994 to 2001 was compiled to obtain the relative use (based on cost) of each pile class. The result, shown in Figure 4.1, shows that Caltrans spends about equal amounts on CIDH and steel pipe piles, with a smaller percentage going to precast concrete piles and H-piles.

The relative use data are used as “weighting” factors later in the analysis.

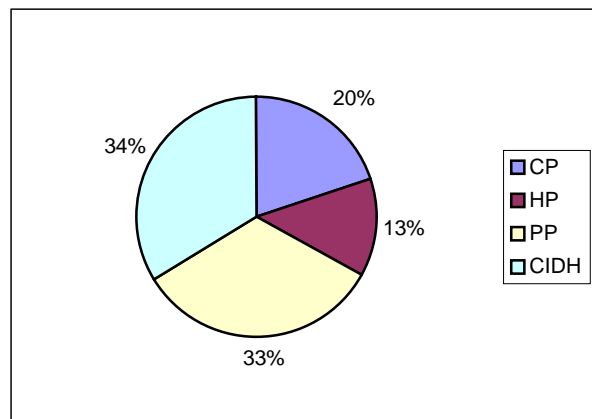

Figure 4.1: Pile spending data, 1994 - 2001

2. Select specific pile types to represent each pile class

The most commonly used pile types within each pile class were selected as most representative and are as follows:

H-piles: HP 14x89

Precast concrete piles: 14"x14" "Class 100" pile with 100 ton design capacity

Steel pipe pile: 24" x 0.5" A-252-grade3 steel (Fy=42ksi)

CIDH: 36-inch diameter

In the case of CIDH piles, the most commonly used pile was 24-inch diameter. However, 36-inch diameter was selected for analysis to reflect larger diameter shafts increasing popularity.

3. Select typical soil profiles for each pile class

Pile selection is controlled not only by design loads and cost, but also by pile drivability. Thus, some types of piles are more common in certain types of soils than others. An example is H-piles. Being more expensive than a comparable precast concrete pile, H-piles tend to be used only in conditions where pile driving is difficult such as dense soils with gravels and cobbles. In an effort to capture this relation between pile type and soil condition, use was made of the Caltrans Pile Load-Test Database. The database contains data from 10 locations incorporating H-piles, 19 locations with precast concrete piles, and 46 locations using steel pipe piles. Although no data was available for CIDH piles, it was assumed that profiles using this foundation type are similar to that of steel pipe piles. For analysis the same profile developed for pipe piles was also used for CIDH piles.

In constructing design profiles, special consideration was given to the top 15-feet of the profile since this zone will strongly influence lateral stiffness and pile moment

demand. Attention was also focused on the pile bearing strata (assumed to be the soil within 5-feet of pile tip) to reflect increased capacity from increased pile length.

The results obtained from the database are as follows:

Depth	Property	H Pile		Concrete Pile		Steel Pipe Pile	
		Mean	Median	Mean	Median	Mean	Median
Top 15'	Sand N60	35.6	22.8	19.3	15.2	16.9	14.4
	Clay Su	2333	2000	1769	1533	933	785
	% Sand	75		55		67	
Middle	Sand N60	55.8	52.3	23	20.4	33.6	27.6
	Clay Su	2490	2267	2122	1824	1457	1500
	% Sand	88		49		44	
	layer thickness (ft)	27.4	25.3	29.9	29.3	44.5	39.7
Pile Tip	Sand N60	78	71.9	39	37.5	64.1	58.5
	Clay Su	2000	2000	2962	2800	2285	2140
	% Sand	98		61		65	

Using this data, soil profiles for the different pile types were constructed and are presented in Appendix B.

4. Use Caltrans cost data to determine typical costs for each foundation type

Following a review of Caltrans bid cost data for the years of 1994 to 2001 the following pile costs were used for the analysis:

Pile Type	Furnish (\$/ft)	Install (\$/each)	Furnish & Install (\$/ft)
HP 14x89	21	1000	N/A
Class 100 Precast	12.50	950	N/A
24" x 0.5" Steel Pipe	55	3000	N/A
36" CIDH	N/A	N/A	215

Pile cap cost estimates were evaluated separately using size of footing to determine concrete, reinforcement, excavation and backfill quantities.

5. Determine pile group size for different loading conditions for each pile type

Utilizing the program GROUP, pile groups were modeled using representative pile types (see Step 2) and corresponding soil conditions (see Step 3). 3 diameter pile spacing was used for piles with diameters less than 24-inches and 2.5 diameter spacing for diameters 24-inches or larger. A Group Reduction Factor ranging from 0.8 to 0.4 depending on group size was applied to the p-y springs of the GROUP model to account for reduced efficiency during lateral loading due to shadowing effects. The contribution of the pile cap to lateral stiffness was considered using a passive wedge analysis.

The fixity condition at the pile/pilecap connection can significantly effect the lateral stiffness of the foundation as well as the moment demand on the pile. Different pile types are typically designed with either a pinned or fixed head condition. For this analysis the following fixity conditions were assumed and represent typical Caltrans design practice:

H piles:	pinned
Precast concrete piles:	pinned
Steel pipe pile:	fixed
CIDH:	fixed

The pile to pilecap connection of the steel pipe pile was assumed to be that of the Cast-In-Steel-Shell (CISS) pile where a reinforcing cage is cast into the top 10 diameters of the pile and developed up into the pilecap. The steel pile itself only extends 5-inches into the bottom of the footing. The moment capacity of such a connection is not well established and is the subject of current research. For this analysis, a moment capacity

of the connection was assumed to be that of the interior reinforced column x 1.25 to account for the added confinement of the steel pile.

Sufficiency of each pile group for the loading condition was based on its ability to withstand static dead load conditions (using a FS=2 for axial load capacity) and seismic demand (uplift and compressive capacity using no factor of safety and moment demand less than the plastic moment of the pile).

Two loading conditions were considered for each group, representing the conditions of a single column and multicolumn bent. In the case of a single column bent, Caltrans practice is to design a fixed connection between the column and the pilecap. In this design the column serves as a “fuse” and the footing is designed to carry the plastic moment of the column. In the case of multicolumn bents Caltrans practice is for the connection to be pinned. In this case no external moment is applied to the footing.

Recommended pile group sizes and costs for each of the four considered pile types and for both single and multicolumn bent configurations are provided in Appendix B. For the case of multicolumn bents, the results are presented in plots depicting the pile group size required to meet axial and lateral load demands. Also shown is the estimated cost of such a pile group including the cost of the pile cap. For single column bents, the results are presented alongside a table of column reactions for columns ranging from 3 to 8 feet in diameter, 1 to 3 percent steel, and axial loads of 900k, 1200k, and 1600k.

Finally, in the GROUP analysis pile lengths were adjusted longer or shorter to best match load demands and minimize foundation costs. However, in the case of precast concrete piles, only pile length shortening was considered since compressive and uplift capacity is limited by the structural strength of the pile. In the case of H-piles, which are typically driven to refusal, pile lengthening is usually not an option and was thus not considered. Shortening H-piles was considered but since the pile's

capacity reduced very quickly with small reductions in length, the effect was small and thus neglected.

6. Calculate Caltrans Average Foundation Cost (CAFC)

$$CAFC = \sum (\text{Cost of Foundation})_i * (\text{Relative use of Foundation})_i$$

where i indexes through the 4 foundation types considered.

4.1b. *Sample Calculation*

Single column case: 5-foot diameter columns with 2% steel and axial load of 1200k

From the tables provided in Appendix B (single column case):

HP: 4x4 pile group at \$ 27.1k

Class 100 precast: 4x4 group (piles shortened 10 ft) at \$ 22.6k

24x0.5 PP: 3x3 group at \$56.8k

CIDH: 3x2 group (piles shortened 5 ft) at \$ 70.0k

$$\begin{aligned} CAFC &= \$27.1k * 0.13 + \$22.6k * 0.20 + \$56.8k * 0.33 + \$70.0k * 0.34 \\ &= \$50.6k \end{aligned}$$

Multicolumn case: Axial demand = 3000 kips and lateral demand = 1000 kips

From the plots provided in Appendix B (multicolumn case):

HP: 4x4 pile group at \$ 30.6k

Class 100 precast: 6x5 group (piles shortened 2 ft) at \$ 45.6k

24x0.5 PP: 3x3 group (piles lengthened 5 ft) at \$59.4k

CIDH: 3x3 group at \$ 116.1k

$$\begin{aligned} CAFC &= \$30.6k * 0.13 + \$45.6k * 0.20 + \$59.4k * 0.33 + \$116.1k * 0.34 \\ &= \$72.2k \end{aligned}$$

4.2 Foundation Stiffness

Proper structural analysis of a bridge system requires that foundation stiffness be considered. In its most general form foundation stiffness can be described using a 6x6 matrix. Using single lateral and rotational stiffness values, however, is usually sufficient to adequately capture the effects of a compliant foundation (especially when one considers the amount of uncertainty typically associated with foundation stiffness values). These stiffness values very much depend on the number and type of piles used as well as the type of soil they are in. Since using calculated stiffness values for each pile group and pile type considered in the foundation analysis would result in a very large multiplication of the number of structure designs to be evaluated, one set of average values was used for all structural analysis.

Results of the foundation analysis indicated that lateral stiffness values ranged from 150 kips/in for a 3x3 Class 100 concrete pile group to more than 2800 kips/in for a 6x5 24x0.5 steel pipe pile group. It is suggested that a value of 750 kips/in is a reasonable value for structural analysis.

Rotational stiffness varied from 2.3×10^5 kip-ft/rad for a 3x3 a 3x3 Class 100 concrete pile group to 2.6×10^7 kip-ft/rad for a 6x5 24x0.5 steel pipe pile group. A recommended value for structural analysis is 10^6 k-ft/rad.

5. COST VS. GROUND MOTION LEVEL

The cost vs. ground motion level analyses resulted in a series of charts illustrating the relationship between estimated cost and ground motion level for each bridge. The cost charts are presented and discussed here; the detailed calculations supporting the charts are included in Appendix C (bridge design spreadsheets), Appendix D (quantity and cost summary) and Appendix E (Cost Curves). In all cases, bridge designs with similar or lower seismic resistance, but with higher cost, are omitted from the charts and the discussions.

For ease of comparison between bridge types, the charts presented and discussed here are in terms of

1. Cost (expressed as dollars per square foot) vs. Spectral Acceleration S_a
2. Cost (expressed as dollars per square foot) vs. Peak Ground Acceleration PGA

5.1 Bridge 1: Straight CIP PT Box Girder, 150 ft Span, 39 ft Width

The bridge cost data points and trend lines derived from the design, analysis, and cost estimating of Bridge Type 1 are shown in Fig. 5.1.

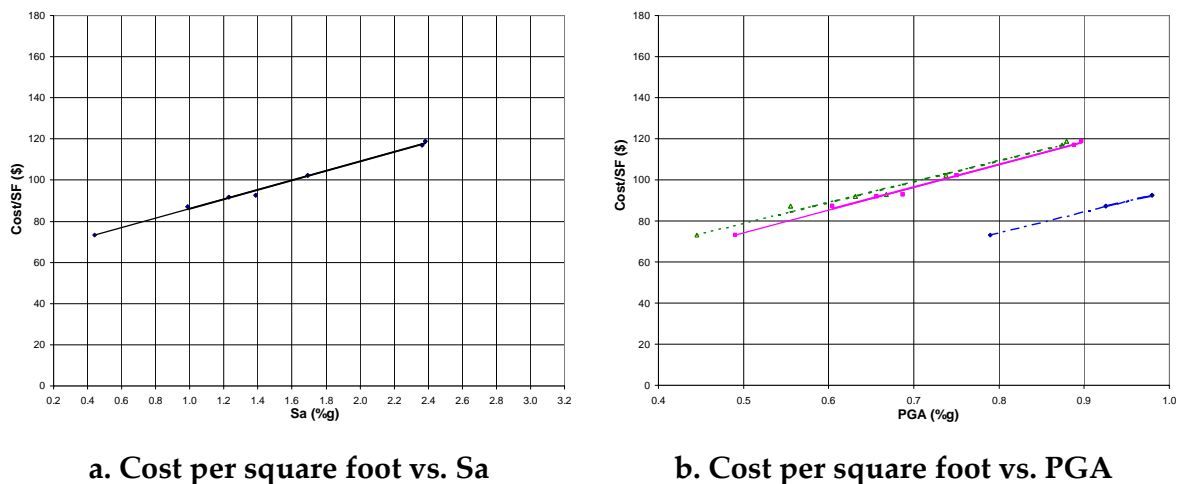

**Fig. 5.1: Cost vs. Ground Motion Intensity, Magnitude 6.5, 7.25 & 8 Events
Bridge Type 1 (Straight CIP PT Box Girder, 150 ft Spans, 39 ft Width)**

The minimum and maximum column sizes were determined by the guideline that $0.67 < D_c/D_s < 1.33$ per SDC Section 7.6.1. Within the restrictions of those column dimensions and reinforcement limits of between one and three percent vertical steel, the bridge lateral force (S_a) resistance ranged from 0.44g to 2.4g. There were no further cost savings for this bridge below a PGA of about 0.45 g, due to the minimum column dimension and reinforcement requirements. The design of the bridge for PGA as high as 1.0g did not encounter any issues to cause rapid cost increases; i.e. no upper bound on feasible seismic resistance was found below a PGA of 1g.

These cost curves imply that for Bridge Type 1, a ten percent increase in design PGA will result in a cost increase of seven to eight percent.

5.2 Bridge 3: Straight CIP PT Box Girder, 100 ft Span, 39 ft Width

The bridge cost data points and trend lines derived from the design, analysis, and cost estimating of Bridge Type 3 are shown in Fig. 5.2.

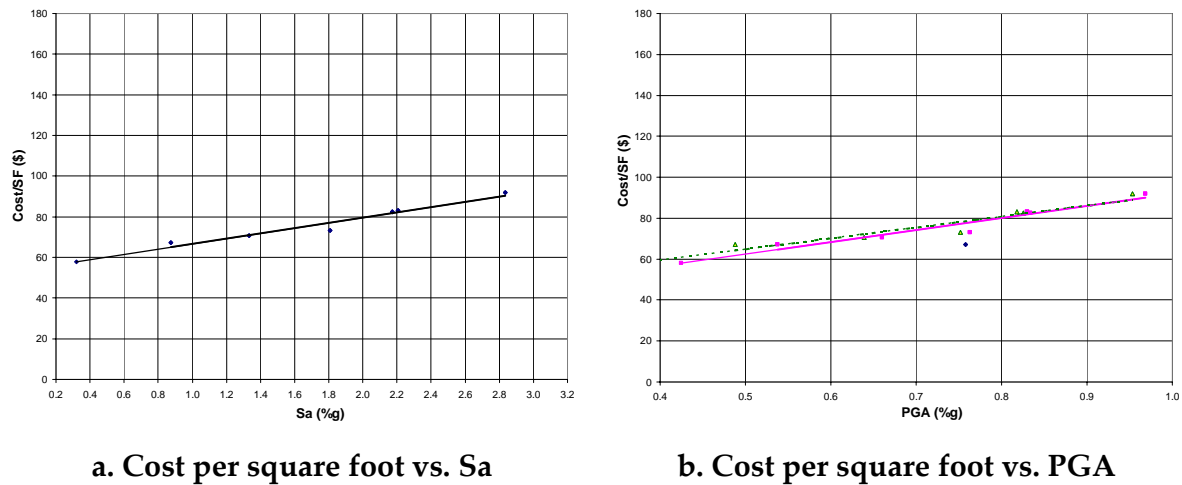

**Fig. 5.2: Cost vs. Ground Motion Intensity, Magnitude 6.5, 7.25 & 8 Events
Bridge Type 3 (Straight CIP PT Box Girder, 100 ft Spans, 39 ft Width)**

The minimum and maximum column sizes were determined by the guideline that $0.67 < D_c/D_s < 1.33$ per SDC Section 7.6.1. Within the restrictions of those column dimensions and reinforcement limits of between one and three percent vertical steel,

the bridge lateral force (S_a) resistance ranged from 0.32g to 2.85g. There were no further cost savings for this bridge below a PGA of about 0.37 g, due to the minimum column dimension and reinforcement requirements. The design of the bridge for PGA as high as 1.0g did not encounter any issues to cause rapid cost increases; i.e. no upper bound on feasible seismic resistance was found below a PGA of 1g.

These cost curves imply that for Bridge Type 3, a ten percent increase in design PGA will result in a cost increase of four to six percent.

5.3 Bridge 4: Straight CIP PT Box Girder, 100 ft Span, 68 ft Width

The bridge cost data points and trend lines derived from the design, analysis, and cost estimating of Bridge Type 4 are shown in Fig. 5.3.

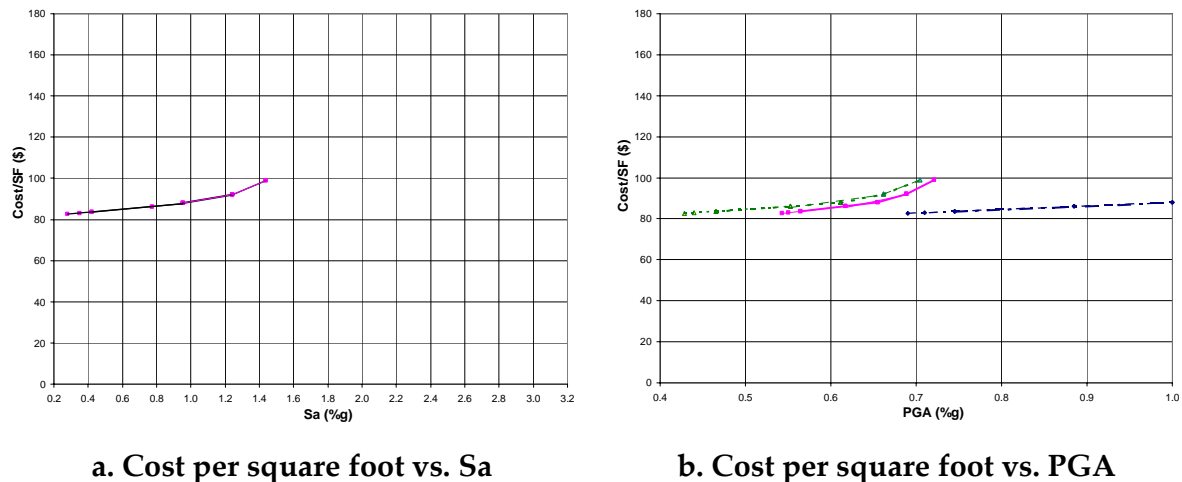

Fig. 5.3: Cost vs. Ground Motion Intensity, Magnitude 6.5, 7.25 & 8 Events Bridge Type 4 (Straight CIP PT Box Girder, 100 ft Spans, 68 ft Width)

The minimum and maximum column sizes were determined by the minimum lateral load (0.1g) requirement, and the guideline that $0.67 < D_c/D_s < 1.33$ per SDC Section 7.6.1. Within the restrictions of those column dimensions and reinforcement limits of between one and three percent vertical steel, the bridge lateral force (S_a) resistance ranged from 0.28g to 1.4g. There were no further cost savings for this bridge below a PGA of about 0.43 g, due to the minimum lateral load (0.1g) requirement, and the

minimum column dimension and reinforcement requirements. The design of the bridge for PGA as high as 1.0g did not encounter any issues to cause rapid cost increases; i.e. no upper bound on feasible seismic resistance was found below a PGA of 1g.

These cost curves imply that for Bridge Type 4, a ten percent increase in design PGA will result in a cost increase of two to three percent.

5.4 Bridge 6: Straight Precast PT I Girder, 100 ft Span, 68 ft Width

The bridge cost data points and trend lines derived from the design, analysis, and cost estimating of Bridge Type 6 are shown in Fig. 5.4.

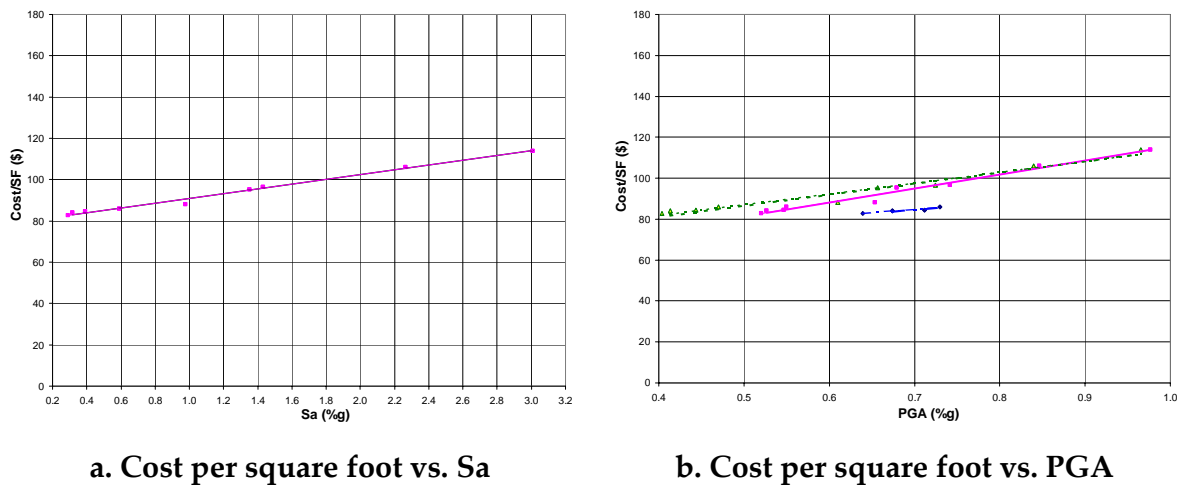

**Fig. 5.4: Cost vs. Ground Motion Intensity, Magnitude 6.5, 7.25 & 8 Events
Bridge Type 6 (Straight Precast PS I Girder, 100 ft Spans, 68 ft Width)**

The minimum and maximum column sizes were determined by the guideline that $0.67 < D_c/D_s < 1.33$ per SDC Section 7.6.1. Within the restrictions of those column dimensions and reinforcement limits of between one and three percent vertical steel, the bridge lateral force (S_a) resistance ranged from 0.29g to 3.0g. There were no further cost savings for this bridge below a PGA of about 0.4 g, due to the minimum column dimension and reinforcement requirements. The design of the bridge for PGA as high

as 1.0g did not encounter any issues to cause rapid cost increases; i.e. no upper bound on feasible seismic resistance was found below a PGA of 1g.

These cost curves imply that for Bridge Type 6, a ten percent increase in design PGA will result in a cost increase of three to five percent.

5.5 Bridge 9: Curved CIP PT Box Girder, 150 ft Span, 27 ft Width

The bridge cost data points and trend lines derived from the design, analysis, and cost estimating of Bridge Type 9 are shown in Fig. 5.5.

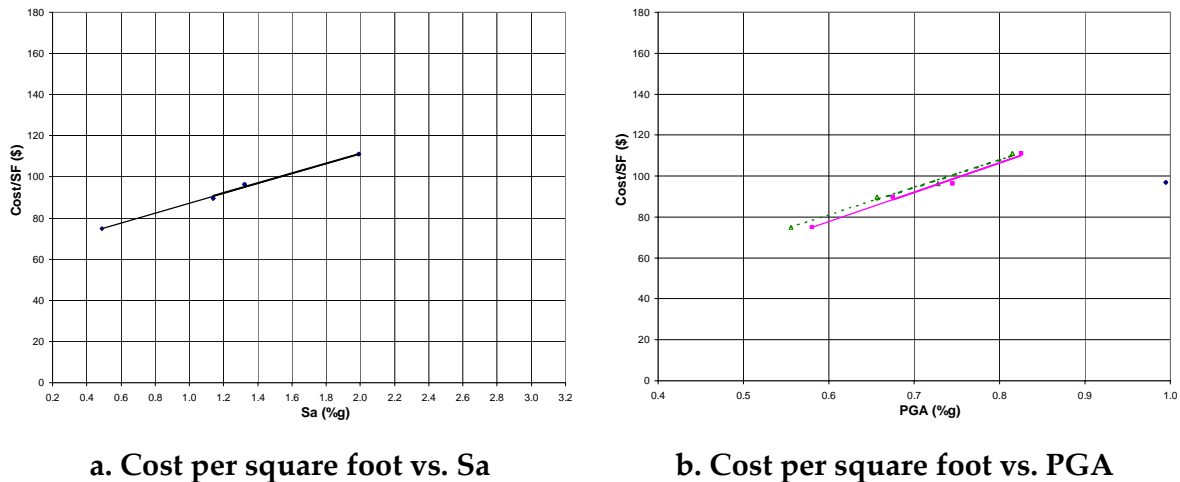

a. Cost per square foot vs. Sa **b. Cost per square foot vs. PGA**
Fig. 5.5: Cost vs. Ground Motion Intensity, Magnitude 6.5, 7.25 & 8 Events
Bridge Type 9 (Curved CIP PT Box Girder, 150 ft Spans, 27 ft Width)

The minimum and maximum column sizes were determined by the guideline that $0.67 < D_c/D_s < 1.33$ per SDC Section 7.6.1. Within the restrictions of those column dimensions and reinforcement limits of between one and three percent vertical steel, the bridge lateral force (S_a) resistance ranged from 0.49g to 2.0g. There were no further cost savings for this bridge below a PGA of about 0.56 g, due to the minimum column dimension and reinforcement requirements. The design of the bridge for PGA as high as 1.0g did not encounter any issues to cause rapid cost increases; i.e. no upper bound on feasible seismic resistance was found below a PGA of 1g.

These cost curves imply that for Bridge Type 9, a ten percent increase in design PGA will result in a cost increase of ten to eleven percent.

5.6 Bridge 10: Skew CIP PT Box Girder, 100 ft Span, 68 ft Width

The bridge cost data points and trend lines derived from the design, analysis, and cost estimating of Bridge Type 10 are shown in Fig. 5.6.

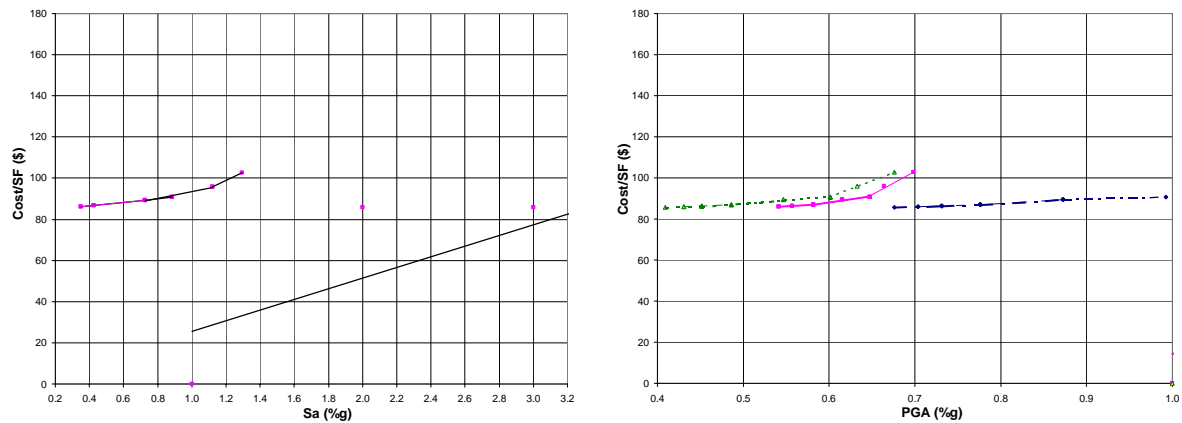

a. Cost per square foot vs. Sa

b. Cost per square foot vs. PGA

**Fig. 5.6: Cost vs. Ground Motion Intensity, Magnitude 6.5, 7.25 & 8 Events
Bridge Type 10 (Skew CIP PT Box Girder, 100 ft Spans, 68 ft Width)**

The minimum and maximum column sizes were determined by the guideline that $0.67 < D_c/D_s < 1.33$ per SDC Section 7.6.1. Within the restrictions of those column dimensions and reinforcement limits of between one and three percent vertical steel, the bridge lateral force (Sa) resistance ranged from 0.29g to 1.3g. There were no further cost savings for this bridge below a PGA of about 0.43 g, due to the minimum column dimension and reinforcement requirements. The design of the bridge for PGA as high as 1.0g did not encounter any issues to cause rapid cost increases; i.e. no upper bound on feasible seismic resistance was found below a PGA of 1g.

These cost curves imply that for Bridge Type 10, a ten percent increase in design PGA will result in a cost increase of one to two percent.

5.7 Bridge 11: Straight CIP PT Box Girder, 150 ft Span, 39 ft Width, Tall Columns

The bridge cost data points and trend lines derived from the design, analysis, and cost estimating of Bridge Type 11 are shown in Fig. 5.7.

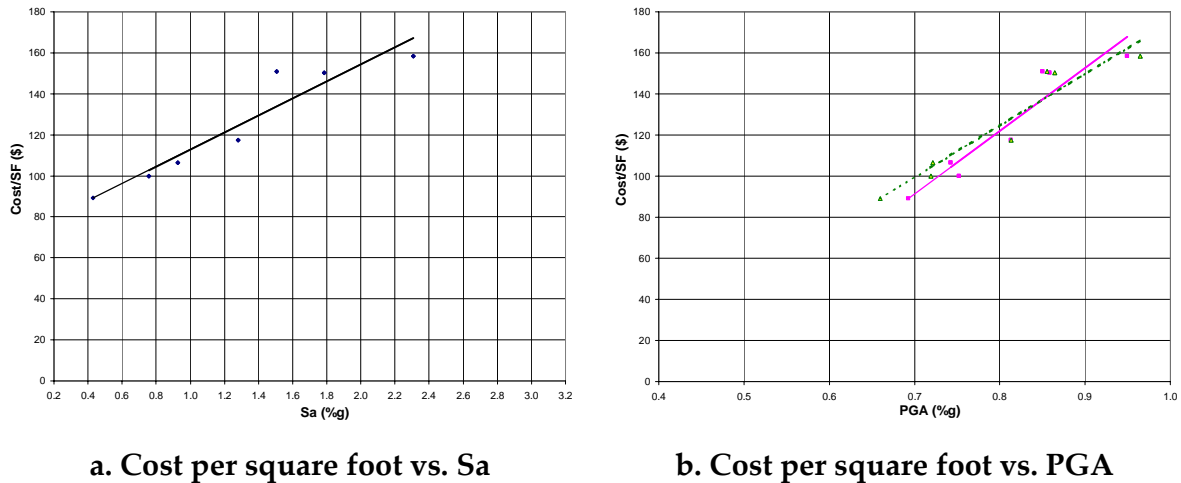

**Fig. 5.7: Cost vs. Ground Motion Intensity, Magnitude 6.5, 7.25 & 8 Events
Bridge Type 10 (Straight CIP PT Box Girder, 150 ft Spans, 39 ft Width, Tall Columns)**

The minimum and maximum column sizes were determined by the guideline that $0.67 < D_c/D_s < 1.33$ per SDC Section 7.6.1. Within the restrictions of those column dimensions and reinforcement limits of between one and three percent vertical steel, the bridge lateral force (S_a) resistance ranged from 0.43g to 2.3g. There were no further cost savings for this bridge below a PGA of about 0.66 g, due to the minimum column dimension and reinforcement requirements. The design of the bridge for PGA as high as 1.0g did not encounter any issues to cause rapid cost increases; i.e. no upper bound on feasible seismic resistance was found below a PGA of 1g.

These cost curves imply that for Bridge Type 11, a ten percent increase in design PGA will result in a cost increase of fourteen to sixteen percent.

5.8 Comparison of All Evaluated Bridge Types

The bridge cost data points and trend lines derived from the design, analysis, and cost estimating of all the bridge types considered in this study are superimposed in Fig. 5.8 and Fig. 5.9.

Cost per square foot vs. S_a and Cost per Square foot vs. PGA for all the bridge types considered in the study are shown in Fig. 5.8. While the cost trends reported for the individual bridge types discussed previously in this chapter are still evident in this figure, trends in terms of percent increase in bridge cost per percent increase in ground motion intensity across bridge types are difficult to discern because of the difference in baseline costs for the different bridge types. For example, at S_a of about 1.0g and PGA of about 0.8g, bridge type 3 costs about \$10 per square foot less, and bridge type 11 costs about \$10 per square foot more, than the more similar costs of bridge types 1, 4, 6, 9, and 10. It is apparent from this figure that bridge type 11 – the concrete box girder bridge with tall columns typical of a high overpass – is subject to much higher cost escalation at high PGA than the other bridge types.

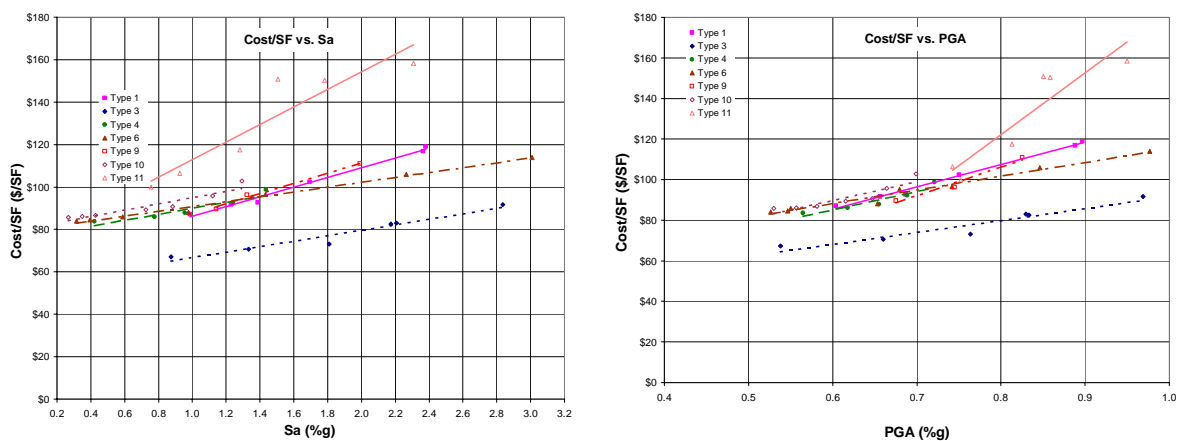

a. Cost per square foot vs. S_a

b. Cost per square foot vs. PGA

Fig. 5.8: Cost vs. Ground Motion Intensity, Magnitude 6.5, 7.25 & 8 Events – All Evaluated Bridge Types

In an attempt to remove the difference in baseline costs of the different bridge types from the cost comparisons, the bridge costs were normalized to a unit value at a nominal value of S_a and PGA. These normalized bridge cost ratios are shown in Fig. 5.9. For Fig. 5.9a (Cost vs. S_a), the cost ratio for each bridge type is defined as cost per square foot divided by the cost per square foot of that bridge type at S_a of about 1.1g. For Fig. 5.9b (Cost vs. PGA), the cost ratio for each bridge type is defined as cost per square foot divided by the cost per square foot of that bridge type at PGA of about 0.69g. The divisor is described here approximately because of differences between the values of the trend lines and the values of the interpolated data.

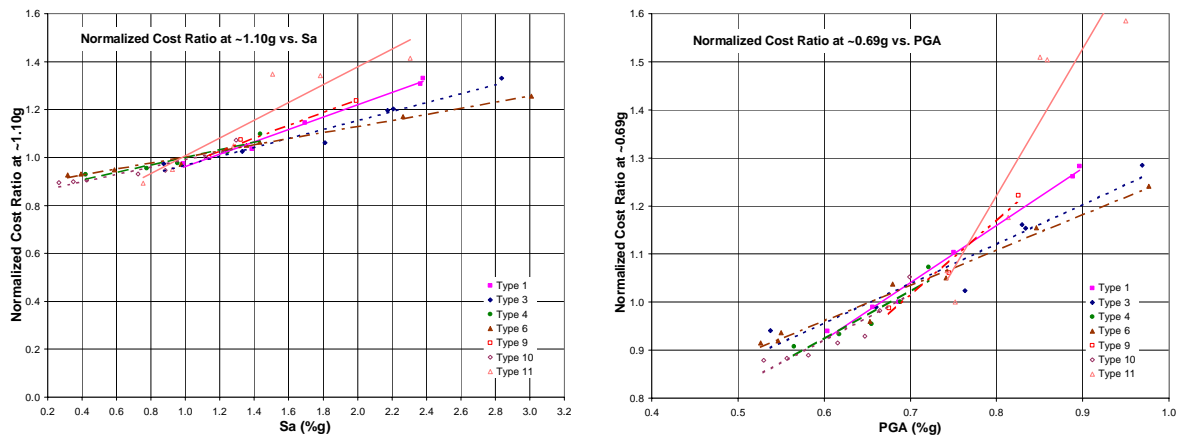

a. Normalized Cost vs. S_a

b. Normalized Cost vs. PGA

Fig. 5.9: Normalized Cost vs. Ground Motion Intensity, Magnitude 6.5, 7.25 & 8 Events – All Evaluated Bridge Types

Three basic cost escalation groups or categories are evident in Fig. 5.9:

1. A low cost escalation group, with cost escalation of about two to five percent per ten percent increase in PGA. This group consists of the 100 ft span bridges, bridge types 3, 4, 6, and 10.
2. A slightly higher cost escalation group, with cost escalation of about eight to ten percent per ten percent increase in PGA. This group consists of the 150 ft span bridges, bridge types 1 and 9.

3. A much higher cost escalation group, with cost escalation of about fifteen percent per ten percent increase in PGA. This “group” consists of one bridge type, the tall column bridge, type 11.

To arrive at a widely applicable and fairly accurate rule of thumb for estimating bridge construction cost as influenced by design earthquake ground motion level, the following observations were taken into account in further interpretation of the data:

1. The baseline bridge costs for this study are considered somewhat low for the actual total construction bid price for the bridges considered. This is because any additional costs usually associated with bridge construction projects, such as site improvements, etc., were neglected.
2. Some statistical variation in bridge costs can be expected regardless of site conditions and seismic exposure. I.e. there is some statistical spread in the historical unit prices used in generating bridge cost estimates.

For these reasons and to simplify any resulting rule of thumb, the first two escalation groups were merged and the resulting escalation factors were averaged and reduced slightly. On the basis of the limited studies performed in preparation of this report, it is concluded that

- For low-overhead concrete bridges, construction cost escalates about five percent per ten percent increase in PGA above a baseline cost at 0.3g to 0.4 g PGA.
- For tall concrete box girder bridges, construction cost escalates about ten to twelve percent per ten percent increase in PGA above a baseline cost at 0.6g to 0.7 g PGA.

5.9 Lower Limits on Sa and PGA

The lower limits on Sa and PGA that were derived from these studies for each bridge type are summarized in Table 5.1. These lower bounds on seismic resistance of bridges designed to the Caltrans SDC are due to the restriction on column size given in SDC equation 7.24 ($0.67 < D_c/D_s < 1.33$); the restriction on column reinforcement given in SDC Section 3.7 ($0.01 \leq \rho \leq 0.04$); and the restriction on lateral flexural capacity given in SDC Section 3.5 (lateral force of $0.1 \times$ tributary dead load).

Table 5.1: Lower Limits on Sa and PGA

Bridge Type	Bent Columns	Column Height	Min Sa	Min PGA
1	1	22'	0.44	0.45
3	1	22'	0.32	0.37
4	3	22'	0.28	0.43
6	3	22'	0.29	0.40
9	1	22'	0.49	0.56
10	3	22'	0.29	0.43
11	1	50'	0.43	0.66

The lower limits on Sa are about 0.3 for the multi-column bents and are somewhat higher – up to 0.49 – for the single column bents. It appears that a bridge designed for seismic resistance using force/moment-demand methods evaluates adequately for significantly higher effective accelerations – about three times higher for multi-column bents and as much as five times higher for single column bents.

The lower limits on PGA exhibit significant scatter, due in part to the varying dynamic properties of the bridges. The baseline PGA of 0.66 g for the tall single column bridge is due to its flexibility and long period. The other bridge types fall at different periods on the ARS curves so there is no direct correlation between Sa and PGA.

6. SUMMARY AND CONCLUSIONS

6.1 *Summary*

A series of design, seismic evaluation, and cost estimating studies was performed to provide an improved understanding of the influence of design ground motion level on construction costs of routine concrete bridges typically used in California highway construction. The studies addressed the most commonly used bridge types and foundation types, under varying levels of ground motions for Magnitude (Mw) 6.5, 7.25, and 8 associated with Caltrans soil profile type D.

The following bridge types were considered, to provide results that are applicable to the most frequently used bridge structures in new California highway construction:

- Straight CIP PT Box Girder, 150 ft Span, 39 ft Width, 22 ft Columns
- Straight CIP PT Box Girder, 100 ft Span, 39 ft Width, 22 ft Columns
- Straight CIP PT Box Girder, 100 ft Span, 68 ft Width, 22 ft Columns
- Straight Precast PT I Girder, 100 ft Span, 68 ft Width, 22 ft Columns
- Curved CIP PT Box Girder, 150 ft Span, 27 ft Width, 22 ft Columns
- Skew CIP PT Box Girder, 100 ft Span, 68 ft Width, 22 ft Columns
- Straight CIP PT Box Girder, 150 ft Span, 39 ft Width, 50 ft Columns

Foundation types that were considered included H-piles, precast concrete piles, steel pipe piles, and CIDH shafts. The foundations were considered using an averaging procedure based on relative use across the state, to arrive at representative costs, strengths, and structural properties representative of statewide averages. The statewide averages were then used in evaluation of each bridge type.

A bridge design and analysis protocol was developed and applied to each bridge type that provided data points and trend lines of bridge cost vs. spectral acceleration (Sa) and bridge cost vs. peak ground acceleration (PGA) for each bridge type. The data points were estimated and presented as plots of cost per square foot vs. Sa and PGA

for each bridge type individually and for all bridge types superimposed on one plot. For better comparisons across bridge types, additional plots were prepared of normalized costs for all bridge types, where cost were normalized to a unit value at an S_a of 1.1g and a PGA of 0.69g.

On the basis of the analyses and plots, estimations of percent increase in bridge cost per percent increase in S_a or PGA were evaluated and noted.

6.2 Conclusions

On the basis of the studies performed in preparation of this report, it is concluded that

- For low-overhead concrete bridges, construction cost escalates about five percent per ten percent increase in PGA above a baseline cost at 0.3g to 0.4 g PGA.
- For tall concrete box girder bridges, construction cost escalates about ten to twelve percent per ten percent increase in PGA above a baseline cost at 0.6g to 0.7 g PGA.

The lower cutoff on cost escalation was typically defined by the Caltrans SDC section 3.5 requirement that the columns or bents have a minimum lateral flexural capacity adequate to resist ten percent of the dead load axial force in the column or bent. Since this SDC design requirement is constant under the varying ground motion levels that were considered, it can be concluded that relaxing this requirement would lower the baseline PGA.

An upper cutoff on the applicability of the increase rates had been expected to be found. This would occur if column sizes were large enough to, for example, require deepening of the girder. However, using the maximum column sizes allowed by application of SDC equation 7.24 did not require deepening of the girder. In a few

cases, the bent cap was deepened and the deck and soffit slabs were thickened near the bent cap in order for the superstructure to have adequate strength to resist the plastic moment of the column. These strengthening measures did not result in appreciable steepening of the cost curves.

6.3 Suggestions for Further Research

Several extensions of the research program reported here could provide additional data applicable to the influence of design ground motion level on highway bridge costs both in California and elsewhere. These include

1. Completion of the cost studies on the remainder of bridge types included in the Bridge Type Matrix but not completed under this study. This would extend the applicability of the findings to a broader range of common structures.
2. Completion of similar cost studies for less frequently used structure types. Candidate types include steel plate girders (used sometimes for very tall structures or at sites with high seismic exposure, where the high escalation rates of heavier structures result in high costs), and slabs on pile extensions.
3. Completion of similar cost studies but with relaxation of the minimum column size requirement and minimum lateral force requirement. Such a study would help illustrate the construction cost impact of these requirements, and extend the usefulness of the findings to bridges built in regions where such minimum requirements may not be applicable.

Since a large part of this project was in developing the bridge design and analysis protocol that was subsequently applied to all bridge types considered, the extensions discussed above could be undertaken relatively quickly and economically and provide reasonable cost / benefit.

7. ACKNOWLEDGMENTS

This research project was sponsored by the Pacific Earthquake Engineering Research (PEER) Center, Program of Applied Earthquake Engineering Research on Lifeline Systems, which is funded by the California Department of Transportation, University of California System, State of California, National Science Foundation, University of Washington System, California Earthquake Authority, California Energy Commission, and Pacific Gas and Electric Company.

The contents of this report reflect the views of the authors who are responsible for the facts and the accuracy of the data presented herein. The contents do not necessarily reflect the official views or policies of the PEER Center or its funders. This report does not constitute a standard, specification or regulation.

The assistance, interest and support of the engineering staff of Caltrans is gratefully acknowledged, especially that of Tom Shantz of the Foundation Engineering Branch along with Sue Hida and Fadel Alameddine of the Division of Structures.

The work of James Scheld and Leo Chien of OPAC Consulting Engineers was also of great assistance to the project.

APPENDIX A: BRIDGE PLANS

APPENDIX B: FOUNDATION ASSESSMENT CHARTS & TABLES

APPENDIX C: DESIGN SPREADSHEETS

APPENDIX D: QUANTITY AND COST SUMMARY

APPENDIX E: COST CURVES